

FIG. 2

Pour sand into the filter tank, distributing evenly. Stop filling about 1/2" from the top flange. Set the remainder of required sand aside for now. Clean off any sand that might be on the flange or in the O-Ring groove before installing the tank O-Ring (22) into O-Ring groove. Remove the bag and rubber band on the center pipe. Replace cover on tank aligning index tabs and sockets. Note: Index tabs must be aligned with sockets, or tank cover will not seal properly (See Fig. 3).

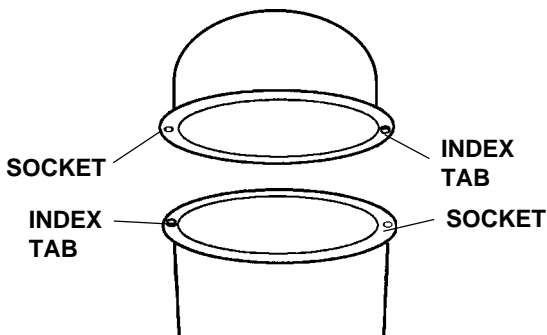

FIG. 3

Install all bolts (20), washers (21) and nuts (30). Tighten bolts and nuts in a uniform manner opposite each other while working around the tank. Remove top tank plug (17) and O-Ring (18) and set aside. Construct a funnel from heavy paper or lightweight cardboard (See Fig. 4). Place funnel in opening and pour the remaining sand directly into tank. It will be easier to use a small can instead of pouring directly from bag. When all the sand is in the tank, clean sand off plug and O-Ring seat area. Replace tank plug and O-Ring.

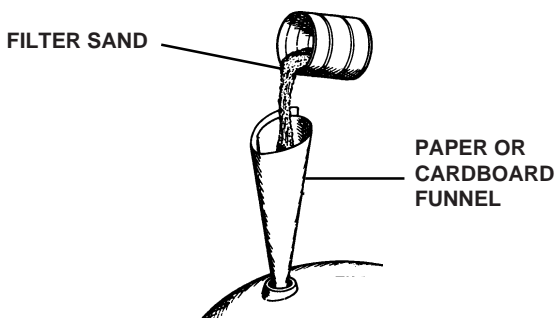

FIG 4.