



Sequel I™ Plus

Rotary DE Filter

Models 0-1641-000

Owner's Guide

Doughboy's Sequel I™ Plus Filter makes routine pool care easier, faster and more convenient. Sequel I™ Plus skim small particles, dust and debris from the pool surface. This debris, with the water, is processed through a filtering element and clean, clear, polished water is returned to the pool. This filtering system, combined with proper pool chemistry, will keep your pool sparkling. Follow the easy steps below to install your new Sequel I™ Plus Filter. Numbers in parentheses refer to key numbers in the illustration on page 7.

IS YOUR POOL READY?

The pool must be properly erected per Doughboy's Pool Assembly & Installation Instructions. There should be approximately 2 feet of water up the metal wall so the liner is stretched to the proper position for installation of the complete filtering system (skimmer, filter, pump, etc.).

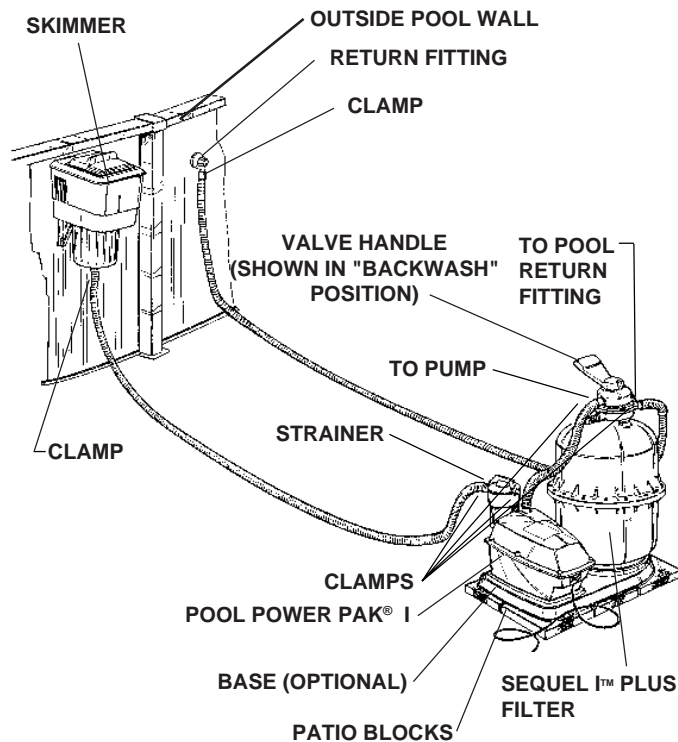

FIG. 1

Tools and Materials You Will Need

Six 14" x 14" patio blocks
 Shovel
 7/16" Wrench
 Flat Head Screwdriver
 Phillips Screwdriver (if optional base is purchased)
 Waste Hose—1 1/2" diameter
 Carpenter's Level

INSTALLING SEQUEL I™ PLUS FILTER

Install the filter and pump approx. 5 feet from the pool wall so they may not be used as steps by children.

Filtering system must sit on a firm, level pad. Patio blocks are the best and easiest material to use for the pad. Any material that is firm and level is acceptable. This pad gives firm support to your Sequel I™ Plus, and allows easy maintenance. It keeps grass from blocking air to the Pool Power Pak®, and keeps standing water away from electrical parts. Use six 14" x 14" patio blocks to make a pad large enough so your Sequel I™ Plus, Power Pak and base (if purchased) can sit without tipping. Use a shovel and carpenter's level to level ground before placing blocks if necessary.

**PICK UP PHOTO
 FROM 365-1724**

MOUNTING STRAINER ASSEMBLY ON POOL POWER PAK

Thread strainer assembly (33) into pump suction port on the Pool Power Pak. Take care to prevent cross-threading. Do not overtighten. The strainer should be snug and in an upright position. You will not use the hose fitting adaptor supplied with your Power Pak. The strainer assembly replaces it with the Sequel I™ Plus Filter.

INSTALLING SEQUEL I™ PLUS FILTER & POWER PAK

Pool must be assembled with skimmer and return fitting installed. Place the Sequel I™ Plus Filter and Power Pak on a firm, level pad such as patio blocks (See Fig.1). **OPTIONAL BASE:** If you purchased Doughboy's corrosion resistant Filter Base or Pump Base, read the Filter or Pump Base Owner's Guide for installation instructions.

HOSE INSTALLATION

(See Fig. 1 and Exploded Parts Illustration)

IMPORTANT: Incorrect hose installation could cause damage to your filter system. Follow the instructions below carefully.

Suction and return lines should be partially buried to

prevent accidental tripping that could cause personal injury or damage to the filter system. Starting at least 12" from the pool wall, make two 3-4" deep trenches, one from the pool skimmer to the front of pump and the other from the pool return fitting to the filter return port.

The two 8 ft. long hoses (41) are interchangeable and used for the suction and return lines. Slip a hose clamp over the ends of each hose prior to installing. Connect one long hose (suction line) between the pool skimmer and front port of pump. Connect the other long hose (return line) between the pool return fitting and the filter return port. Connect the short hose (6) between the pump discharge port (located at top of pump) and the filter pump port. Tighten clamps firmly using a flathead screwdriver or 5/16" nutdriver. Cover the trenches with a firm board when finished.

NOTE: Do not completely bury the hoses with dirt.

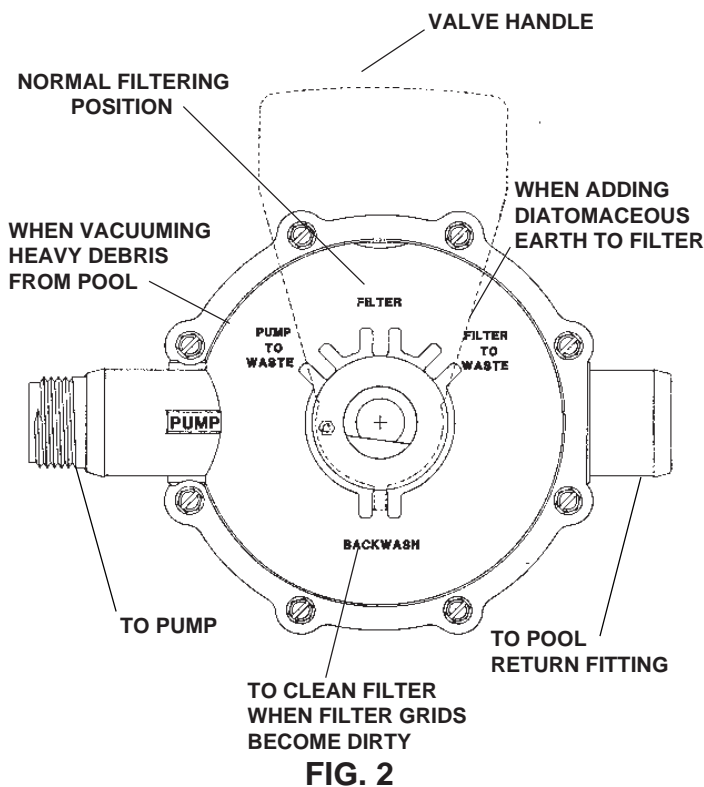

SEQUEL I™ PLUS OPERATING POSITIONS

Your new Sequel I™ Plus Filter has four positions of operation, which are explained below. To change positions on the filter, make sure the pump is "OFF". Press down on the filter handle enough to free the locking tab. Rotate the handle so the tab locks in the desired position. The locking tab indicates the filter position. The tab must be locked into one of the four slots for the filter to operate correctly (FIG. 2).

FILTER POSITION

(Normal running position for filtering pool water.) The length of filtering time depends on: pool size, pool use, amount of airborne dust and debris, and chemical

treatment. High wind locations will cause a pool to get dirty faster, requiring longer filtering time. Failure to give your pool proper chemical treatment will also require additional filtering time. Your pool dealer can help you determine proper filtering times, general maintenance and chemical treatment for your pool.

NOTE: Always keep the water level in your pool between the water level markers on the skimmer faceplate.

BACKWASH POSITION

Backwashing reverses the flow of water, cleaning dirt and debris from the filter. How often you backwash the filter will vary with pool size, pool use, amount of airborne dirt and debris, and the chemical treatment you give the water. Backwashing should be done when the Sequel I™ Plus pressure gauge reads 5 to 7 pounds higher than initial start-up pressure. Example: If the pressure gauge reads 10 pounds at the start of a clean filter, you should backwash when the gauge reads from 15 to 17 pounds.

FILTER TO WASTE POSITION

Place the valve handle in the "Filter to Waste" position after backwashing your Sequel I™ Plus Filter. This will prevent an objectionable "cloudy puff" of D.E. from entering your pool through the pool return inlet.

PUMP TO WASTE POSITION

This position allows you to vacuum heavy debris or larger amounts of settled contaminants from the bottom of your pool directly to waste.

INITIAL START-UP AND OPERATION OF FILTER

The water level in your pool must be between the water level markers on the skimmer faceplate. The pump must be able to draw water from the pool to operate safely. Never run the pump with the pool water level so low that no water passes to the pump. The pump seal may overheat and permanent damage to the pump may occur.

WASTE LINE HOOK-UP

The waste line is used when cleaning (backwashing) and adding D.E. to the filter and requires a 1 1/2" dia. hose connected to the waste port. You may also use a collapsible-type hose obtained from your dealer designed for this purpose. Be sure pump is off. **Remove the waste cap and gasket prior to installing hose on the filter.** Make sure the other end of the hose is located in an area that will accept approximately 100 gallons of water.

ADDING D.E.

Be sure your Sequel I™ Plus valve handle is in the **FILTER TO WASTE** position. Remove waste cap and gasket. Your filter requires 1 1/2 pounds of "diatomaceous earth" (D.E.). This powder coats the grids inside the filter. The coated grids provide the filtering action.

D.E. can be purchased at your local pool store. Remove the skimmer lid. Start your Pool Power Pak. You can use a clean, one-pound coffee can to measure the D.E. NOTE: A one pound coffee can holds 1/2 pound of D.E. Your filter requires three coffee cans full. Slowly pour D.E. into the skimmer. During this process super fine particles of the D.E. migrate through the "V" grids and to waste rather than entering the pool in an objectionable cloudy puff through the return inlet. After 30 seconds, turn pump off and rotate valve handle to the **FILTER** position. Replace skimmer lid in normal position when completed. **Note the clean filter starting pressure on the pressure gauge. NEVER OPERATE FILTER WITHOUT D.E.!**

A newly filled pool usually requires continuous filtering for about 24 hours. The time varies depending on water conditions and amount of water being filtered. During initial start-up, the Sequel I™ Plus may require frequent cleaning (backwashing) as it filters the water. (See "BACKWASHING".) After a few days of operation, and periodically thereafter, recheck all fittings, clamps and screws for tightness. Retighten as necessary.

ROUTINE CARE & MAINTENANCE

FILTERING

For normal filtering, the valve handle is rotated to the **FILTER** position, and the Pool Power Pak is "ON". When you stop your Power Pak, the D.E. slips off the filtering grids and settles to the bottom of the filter tank. When you start your Power Pak, inlet water is directed to the bottom of the filter tank. It sweeps up the settled D.E. and collected debris to recoat the filtering grids. (You may notice a lower reading on the Sequel I™ Plus pressure gauge at this time. Water flowing through the grids meets less resistance from the D. E. and collected debris mixture. This gives you extended filtering time. You don't need to add more D.E.). Backwash the filter when there is a big increase in the pressure gauge reading.

BACKWASHING

1. Stop pump. Be sure drain cap and gasket are removed, and waste line is hooked up to the port labeled "To Waste."
2. Rotate valve handle to **BACKWASH** position. Turn pump "ON" and run for 2-3 minutes or until waste water clears.
3. Stop pump and move valve handle to **FILTER TO WASTE** position, then start pump and run for 20 seconds.
4. Stop pump and repeat steps 2 and 3.
5. Stop pump and move valve handle back to **BACKWASH** position. Start pump and run until waste water is clear.
6. Stop pump, move valve handle to **FILTER TO WASTE** position. Start pump and recharge with

D.E. (See Initial Start-Up of Filter for adding D.E.). Remove waste hose, and replace gasket and drain cap.

TO CLEAN DOUGHBOY STRAINER ASSEMBLY

CLEAN THE STRAINER ASSEMBLY FREQUENTLY. The strainer assembly on your Doughboy Pool Power Pak® catches large debris such as insects and leaves. **To clean:** Stop your Power Pak. Rotate valve handle on your Sequel I™ Plus to **BACKWASH** position. This closes off the pool return line to prevent back flow of water through the filter and out the pump strainer. To prevent water coming from the skimmer, remove skimmer lid and basket. Plug the hole in the bottom of the skimmer with a towel or cloth. Rotate strainer assembly lid counterclockwise until locking tabs are free. Lift lid. Remove basket and clean. Lubricate O-Ring on lid prior to reassembly. (See "LUBRICATION" in this guide.) Remove towel or cloth from skimmer hole. Replace skimmer basket and lid. Rotate valve handle to **FILTER** position and switch Pool Power Pak on to resume normal filter operation.

LUBRICATION

Important: Regularly lubricate the O-Ring on the Power Pak strainer assembly cover and Sequel I™ Plus valve rotor with a NON-PETROLEUM lubricant recommended for A.B.S., Noryl and Acrylic plastics. Consult your pool dealer for lubricant selections. To lubricate the O-Ring on the valve rotor depress valve handle fully and apply lubricant, then rotate handle to distribute lubricant. To resume normal filtering operation, rotate valve handle to **FILTER** position and start pump.

VACUUMING YOUR POOL

Prior to vacuuming, clean out strainer assembly basket on your Power Pak and backwash your Sequel I™ Plus Filter thoroughly. Follow skimmer manufacturer's instructions for vacuuming pool. It may be necessary to backwash your filter frequently during the vacuuming operation. For excessive amounts of dirt on the pool floor, we recommend that you vacuum directly to waste. This is accomplished by installing your waste line (See waste line hook-up) and placing the filter valve handle in the **PUMP TO WASTE** position. Then proceed vacuuming as usual. When you've completed vacuuming, backwash your Sequel I™ Plus thoroughly and clean the strainer basket again. Resume normal filtering operation.

KEEP YOUR POOL SPARKLING

You can take steps to reduce the amount of maintenance needed to keep your pool sparkling.

1. Provide a clean walkway leading to your pool entrance.
2. Rinse off patio and area around pool regularly.

3. Swimmers should rinse off (especially their feet) before entering pool.
4. Maintain the proper chemical balance in your pool. Hot days will cause chemicals to dissipate rapidly.
5. Remove floating leaves and debris with a leaf skimmer.
6. Empty skimmer basket and strainer basket frequently.
7. Vacuum pool bottom to remove settled debris.
8. A pool cover will help keep your pool clean during high winds or rainfall.

DOUGHBOY POOL CARE

Refer to Doughboy's "SAFETY FIRST Pool Use Handbook" for correct use, care, and chemical treatment of Doughboy pools.

CHLORINE INSTRUCTIONS

ALWAYS READ AND FOLLOW CHEMICAL MANUFACTURER'S SAFETY PRECAUTIONS FOR HANDLING CHLORINE

WARNING! DO NOT PLACE CHLORINE TABLETS IN THE SKIMMER BASKET! Putting chlorine tablets directly into the skimmer basket will destroy the pump strainer basket and internal components. We recommend against adding any kind of chemicals directly into the skimmer!

Please read the following instructions carefully. Chlorine is a strong chemical. Improper use could result in serious, permanent damage to the pool liner. This damage could include "white spots", wrinkles or breakage (brittle vinyl). Such damage is not covered under warranty.

IMPORTANT: Pump and Sequel I™ Plus should always be "ON" when adding chemicals to pool water.

WITH DISPENSER

Dry Chlorine (tablets, sticks, granules, or powder). Use one of the following types of chlorine dispensers:

- Floating Dispenser: Use only when pump is running. Dispenser must circulate in pool for safe distribution of chlorine.
- Automatic feeder (in-line or off-line).
- Chlorine generator - Approved for use. Releases chlorine from salt.

Ask your Doughboy dealer to recommend the best type of dispenser for your pool and area conditions. Follow manufacturer's instructions for correct use.

WITHOUT DISPENSER

Dry Chlorine: Use granules or powder only. NEVER pour dry chlorine directly into the pool water. Mix with pool water in a clean plastic container following chlorine manufacturer's safety instructions. When all chlorine has dissolved, pour solution into pool water at the return fitting. Water returning to the pool will properly distribute chlorine.

Liquid Chlorine: Liquid chlorine concentrate may be poured directly into pool water. Carefully add liquid chlorine to water at the return fitting. Water returning to the pool will distribute the chlorine. Follow chemical manufacturer's instructions for use of liquid chlorine.

WINTERIZING (FREEZING CLIMATES)

With Doughboy Skimmer & Return Fitting

Your Sequel I™ Plus Filter must be drained, cleaned and stored indoors for the winter season. We strongly recommend for the protection of your filter, liner and pool wall, that you purchase and install the DOUGHBOY Winterizing Kit (0-2099-001). The proper installation of this kit will allow the removal and storage of your skimmer and filter, and should eliminate any possibility of damage.

CAUTION

Removing the skimmer without installing a winterizing kit is very dangerous to the pool wall, liner and pool installation, and voids any warranty. Filter or pump damage caused by freezing temperatures is not covered by product warranty.

To winterize Sequel I™ Plus: Drain pool water to 6" below return fitting. Rotate valve handle to PUMP TO WASTE position (See Pump To Waste). Turn pump on and run until water level is drawn down to skimmer level. Turn pump **OFF**. Additional water removal can be accomplished by syphoning with several garden hoses, or vacuum hoses.

Remove bottom tank plug (17) and loosen top tank plug to relieve air. Disconnect all hoses after water is completely drained from tank. Remove tank flange bolts (20), or washers (21) and nuts (29). Lift cover off and set aside. Remove the "V" grid collector (25) and all five "V" grids (27). Hose off the "V" grids and inspect for calcium build-up (white crustation). If crustation exists, wash grids with a solution of one part muriatic acid to four parts water. Allow grids to air dry prior to storage. **CAUTION:** Chlorine and acids kill lawn and plant life. Clean grids in a suitable area.

Store your Pool Power Pak and Sequel I™ Plus indoors for the winter season. For spring start-up, follow Hose Installation and Initial Start-Up instructions in this guide.

TROUBLE SHOOTING

A. High gauge pressure, low return flow.

1. Filter requires backwashing.
2. Or, excessive contaminants or algae coated on "V" grids inside filter. Backwash to correct.
3. Calcium crustation in "V" grid cloth. Disassemble filter and wash grids with 1 part muriatic acid to 4 parts water.

B. Low gauge pressure, low flow. Pump suction is drawing in air (noted by bubbles returning to pool), or pump sounds like marbles are rattling in it.

1. Pool water level is too low. SWITCH PUMP "OFF" AT ONCE. Fill pool so water level is between markers on skimmer faceplate.
2. Or, there is a restriction on the suction side of the pump.
3. Or, pump strainer assembly is clogged with debris. Clean strainer assembly.
4. Or, tighten pump strainer assembly lid.

C. High flow, low or normal gauge pressure...but pool water won't clear up.

1. Pool water is chemically out of balance. Use water test kit to check balance.
2. Or, opening in "V" grid cloth.
3. Or, "V" grid assembly inside filter is loose and by-passing water.

D. Very short filtering cycles. Requires backwashing too frequently.

1. Excessive suspended contaminants or algae

in pool water. (Filter will require frequent backwashing until pool clears up.)

2. Calcium crustation in "V" grid cloth. Disassemble filter and wash grids in 1 part muriatic acid to 4 parts water.

E. Cloudy puff coming out of return fitting.

1. Place valve handle in FILTER TO WASTE position when turning on pump and during precoating of D.E..
2. Or, if vacuuming, place valve handle in PUMP TO WASTE position.

F. Water is leaking to waste.

1. Inspect drain cap (38) and gasket (39) for needed repair.
2. Actuate and rotate valve handle to clear seating area of debris.
3. Or, replace valve gasket in valve cover.

G. Filter is backwashing when valve handle is in FILTER position after servicing filter.

1. Valve cover is assembled backwards on tank cover (180° from correct position).

SERVICE

During disassembly of the filter, mark each part's assembled position as it relates to the mating part to assure proper alignment when reassembled. Malfunctioning of the filter will occur if not properly reassembled. Use only original Doughboy replacement parts. See your professional Doughboy pool dealer for Original Equipment Manufactured (OEM) parts and servicing.

PARTS LIST SEQUEL I™ PLUS MODEL 0-1641-000

ITEM	P/N	QTY	DESCRIPTION	ITEM	P/N	QTY	DESCRIPTION
1	340-1764	1	Valve Handle	23	340-1285	1	Adaptor
2	376-1050	1	Handle Pin	24	343-1100	1	Air Relief
3	327-1007	2	Friction Washer - Large	25	1107-1062	1	Grid Collector Assy.
4	330-1174	8	#10-24 x 1" Hex Hd Screw	26	1107-1063	1	Inlet Pipe Assy.
5	387-1003	6	1 1/2" Hose Clamp	27	1111-1012	5	Grid
6	346-1013	1	1 1/2" x 2 1/2" Hose	28	340-1554	1	Tank
7	340-2026	1	Valve Cover	29	321-1021	16	1/4"-20 Hex Flange Nut
8	395-1014	1	Pressure Gauge	30	340-1303	1	Grid Adaptor
9	308-1174	1	"O"-Ring	31	330-1023	1	#8 - 5/8" Hex Hd Screw
10	327-1006	2	Valve Bearing Washer	32	340-1461	1	Deflector
11	396-1018	1	Valve Spring	33	1300-1010	1	Strainer Assy.
12	340-1766	1	Valve Rotor	34	1300-1004	1	Strainer Lid w/Decal
13	308-1182	1	Gasket, Valve Rotor	35	308-1004	1	Strainer "O" Ring
*14	1107-1384	1	Valve Body & Gasket Assy.	36	1300-1002	1	Strainer Basket Assy.
15	321-1064	8	#10-24 Square Nut	37	340-1779	1	Strainer Body
16	308-1109	2	Valve Port Gasket	38	340-1035	1	Drain Cap
17	340-1183	2	Tank Plug	39	307-1001	1	Drain Cap Gasket
18	308-1043	2	"O"-Ring	40	340-1826	2	Friction Washer - Small
19	1121-1329	1	Tank Cover w/Decal	41	346-1035	2	1 1/2" x 8' Hose
20	324-1020	16	1/4-20 x 1 1/4" Hex Hd Bolt	42	—	1	Warranty Card
21	326-1008	16	1/4" Plain Washer	43	365-1724	1	Owners Guide
22	308-1113	1	Tank "O" Ring				

* Item #14 includes #13

EXPLODED PARTS

SEQUEL I™ PLUS FILTER — MODEL 0-1641-000

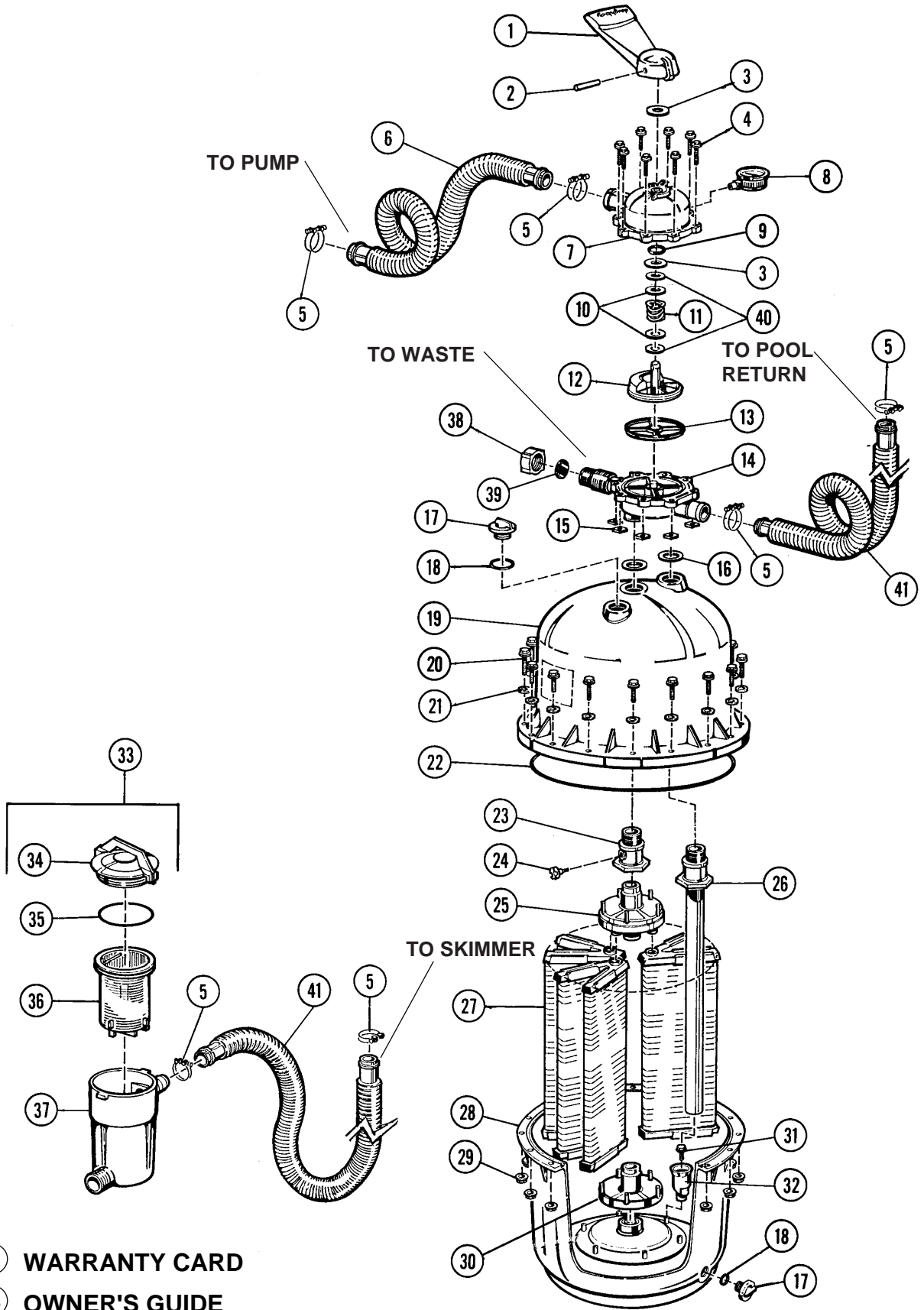

IMPORTANT FILTER/ PUMP SAFETY

1. **DO NOT** install filter or pump on a deck. They could fall into the water, causing severe electrical shock. Do not install on any surface at, above, or slightly below the top rail of the pool.
2. **DO NOT** allow children or adults to climb, sit or stand on the filter or pump units. They could easily fall. Position filter and pump as far from the pool wall as possible so they may not be used as steps by children.

SERVICING SAFETY TIPS

- A. **ALWAYS TURN "OFF"** the main power switch and the Ground Fault Circuit Interrupter (GFCI) breaker switch so power is completely off before servicing your unit.
- B. **ALWAYS STOP PUMP** before you service, tighten, or adjust the filter assembly.
- C. **ALWAYS BE SURE THE GROUND UNDER YOUR FEET, AND YOUR BODY, IS DRY** before you touch filter or pump electrical equipment. Failure to heed this warning may cause personal injury due to severe electrical shock.

- D. **ALWAYS** have a qualified electrician service your system if electrical problems occur.
- E. **ALWAYS** have a qualified electrician install a Ground Fault Circuit Interrupter (GFCI) breaker at the electrical service or supply panel. Follow GFCI manufacturer's operating instructions for testing. Failure to do so may cause personal injury due to severe electrical shock.

CAUTION: To reduce the risk of electrical shock, connect only to grounding type receptacles. A Ground Fault Circuit Interrupter (GFCI) must be provided in accordance with Article 680 of the National Electrical Code (NEC) and local code or ordinances.

CAUTION: To reduce the risk of electrical shock, use only Original Equipment Manufactured (OEM) replacement parts when servicing.



Change of Design: Doughboy Recreational expressly reserves the right to change or modify the design and construction of any product in due course of our manufacturing procedures, without incurring any obligation or liability to furnish or install such changes or modifications on products previously or subsequently sold.

"the original portable pool"
doughboy[®]