



Media Master

Sand Filter with 6 Position Valve

Model 1900 — Item No. 0-1703-019

Model 2200 — Item No. 0-1702-022

Model 2600 — Item No. 0-1702-026

Owner's Guide



*Shown with Power Pak III, not included.



“READ ALL INSTRUCTIONS” Failure to follow these important safety instructions and other basic safety precautions may result in serious personal injury.

IMPORTANT SAFETY INSTRUCTIONS

Before you begin installing your filter, refer to your pump owner's guide for very important installation and electrical information related to your filter.

ELECTRICAL/BUILDING PERMIT

Local building codes may require obtaining an electrical or building permit and may have regulations on setbacks and barriers that **must** be followed.

ELECTRICAL

We recommend you have a qualified electrical contractor install the electrical power supply as specified in your pump instructions.

INSTALLED LOCATION

Position filter, pump and any other related components a minimum of 5 feet from pool to prevent their being used as a means to climb into the pool by young children. **DO NOT** store toys, chairs, tables, containers or other objects within 5 feet of the pool for the same reason.

WARNING

SEVERE ELECTRICAL SHOCK could result if you install your filter and pump on a deck or above pool water level. They could fall into the water, causing severe shock or electrocution. **DO NOT** install on a deck or other surface at, above or slightly below the top rail of the pool.

PROPERLY SUPPORTED

Filter, pump and any other related components should be properly supported to prevent damage from misalignment, settlement, vibration and mounted so as to minimize the potential for the accumulation of debris and moisture.

ACCESSIBILITY

The circulation system components should be installed to allow accessibility for inspection, repair or replacement.

DO NOT alter the pump electrical cord in any way or change the plug end to any style.

DO NOT use an extension cord(s). Severe electrical shock may occur.

PREVENT SEVERE SHOCK

To prevent the risk of severe electrical shock, plug your pump cord end into a grounding type receptacle protected by a ground fault circuit interrupter (GFCI). Contact a qualified electrician if you cannot verify that the receptacle is protected by a GFCI.

DO NOT allow children to operate or play around this product unless they are closely supervised by adults at all times.

Replace damaged cord immediately to reduce the risk of electrical shock.

DO NOT BURY CORD

An exposed cord may accidentally become damaged or severed by a sharp object or shovel resulting in severe electrical shock. Position cord to prevent accidental damage from lawn mowers, hedge trimmers or other equipment.

BARE FEET/WET GROUND

This is a dangerous combination around electrical equipment. Always be sure the ground under your feet and body is dry before you touch electrical equipment. Failure to heed this warning may cause severe personal injury or electrocution due to severe electrical shock.

WARNING

Avoid direct water spraying with a garden hose around electrical outlets, pump or any other electrical devices. Severe electrical shock or electrocution may occur.

SERVICING YOUR PUMP

Always unplug your pump from the receptacle before servicing, adjusting or repairing.

Did you read the **IMPORTANT SAFETY INSTRUCTIONS?** If not, **READ THEM NOW.** They contain very important safety information related to the installation of your filter. Familiarize yourself with the installation sequences by reading these instructions first. **AVOID SHORTCUTS** that may result in reworking the installation.

BEFORE YOU BEGIN

The pool must be properly erected per your pool assembly and installation instructions before installing the filter. Install the surface skimmer and return fitting.

Before completing the filling of the pool to the water level indicator marks on the skimmer face plate, the filter and pump should be installed with all connections secured tightly.

TOOLS REQUIRED

- Flat head screwdriver
- #2 Phillips screwdriver
- 1/2" wrench
- Measuring tape
- Carpenter level
- Flat nose shovel
- Rags
- 5/16" Nutdriver (optional)

The following tools are for Models 2200 and 2600 only:

- Hacksaw
- File

MATERIALS REQUIRED

- Nine 12" x 12" patio blocks
- 3" long rubber band
- Ordinary plastic bag
- #20 grade filter sand:
Model 1900 = 225 lbs.
Model 2200 = 300 lbs.
Model 2600 = 400 lbs.
- Waste hose - 1-1/2" inside diameter (Model 1900 only)

The following materials are for Models 2200 and 2600 only:

- 1-1/2" schedule 40 PVC pipe
Note: Quantity depends on length or pipe runs desired.
- 10 to 12 - 1-1/2" 90 degree socket PVC elbows.
- PVC pipe primer
- PVC to ABS solvent cement with applicator.

INSTALLATION

INSTALLATION LOCATION

Install your filter and pump and any other related components at least 4 feet from the pool to prevent their being used as a means of access to the pool by young children. Patio blocks provide firm support and keep standing water and weeds away from electrical parts. **DO NOT** install your filter and pump directly on the ground surface. Settling and stressing circulation lines may occur during wet seasons. Position patio blocks as illustrated in the following, using a shovel and carpenter's level to level ground before placing the blocks.

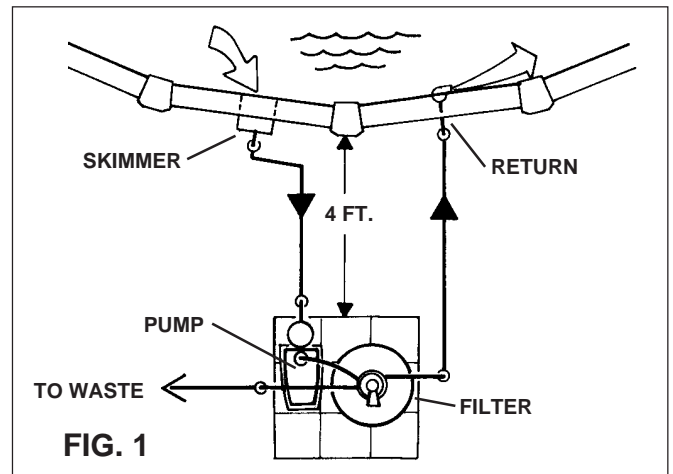

POSITIONING FILTER/PUMP

Position filter base and pump on pad as shown in FIG. 1.

Suction and return lines should be partially buried to prevent accidental tripping that could cause personal injury or damage to the filter system. Starting at least 12" from the pool wall, make two 3-4" deep trenches, one from the pool skimmer to the front of pump and the other from the pool return fitting to the valve port marked "RETURN".

Be sure the hoses are routed so that water flow through them is not restricted.

POSITION FILTER ON BASE

Position filter on the base with the valve port labeled "PUMP" pointing towards the pump discharge.

INSTALL FILTER SAND

Your filter is designed to provide peak performance using #20 grade filter (.4/.5 mm) sand. The sand should be uniform in size and appear as crushed sand with sharp edges. Rounded river bed sand will impair filtering performance. Consult your local pool store.

REMOVE V-CLAMP & COVER Models 2200 & 2600

Unscrew V-Clamp knob counterclockwise to loosen and remove clamp. Lift cover with valve off tank. Remove large o-ring.

REMOVE TANK CLAMP & COVER Model 1900

Loosen clamp screws and remove tank clamp. Lift valve assembly and large o-ring from tank.

COVER RISER TUBE

Slip a plastic bag over the riser tube and secure with rubber band.

INSTALL SAND

Carefully pour filter sand into tank. Refer to "MATERIALS REQUIRED" for quantity required for your filter. Level surface with palm of hand. Remove any sand from plastic bag and tank flange sealing surface. Remove rubber band and plastic bag.

REINSTALL COVER

Position large o-ring on tank flange sealing surface and place valve assembly on top tank, aligning o-ring into cover groove, and riser tube with center of distributor. Install tank clamp, sandwiching cover and tank flanges.

Model 1900: Tighten tank clamp screws securely.

Models 2200 & 2600: Tighten knob until ends of v-clamp are less than 3/8" apart.

INSTALL PUMP DISCHARGE HOSE

The pump discharge hose is provided with a hose barbed fitting and a 1-1/2" pipe socket fitting. Install the hose barbed fitting to the pump discharge per the pump instructions and discard the socket fitting unless your option is to hard plumb this connection with PVC pipe. (Refer to "Option For Hard Plumbing"). Slip a hose clamp over each end of hose prior to installing. Push each hose end fully onto the valve port label "PUMP", then tighten clamps firmly using a flat head screwdriver or 5/16" nutdriver..

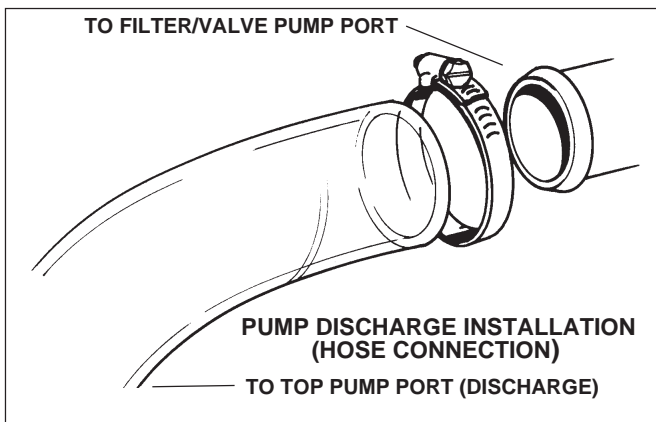

OPTION FOR HARD PLUMBING

If your option is to hard plumb the pump discharge to filter line, it will be necessary that you order a "hard plumb" adaptor (P/N 348-1036) and one "Clamp" (P/N 387-1024). Refer to "Hard Plumb Installation" for PVC piping assembly, then install as shown.

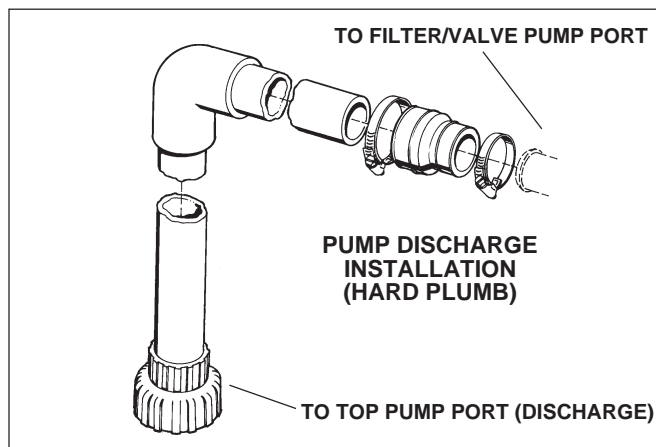

INSTALL RETURN LINE

An 8 foot long hose is provided for filter Model 1900 and a special high flow return fitting with filter Models 2200 and 2600 for adapting hard plumbing for the return line.

MODEL 1900 ONLY

Slip a hose clamp over the ends of the hose and push one end onto the filter valve **RETURN** port and the other

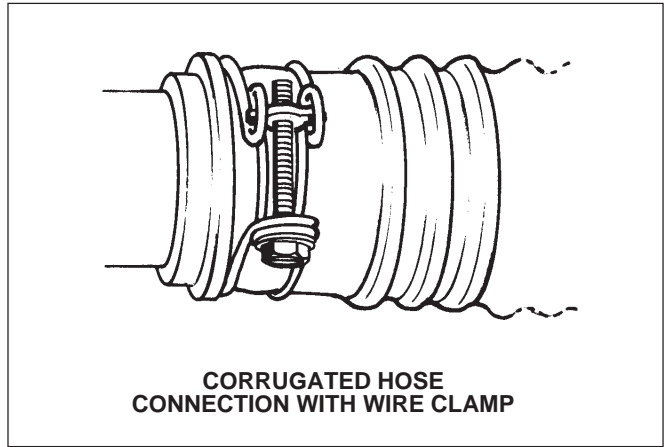

end onto the **POOL RETURN** fitting. Tighten clamps firmly using a flathead screwdriver or 5/16" nutdriver.

MODELS 2200 AND 2600

These filter models are designed for a hard plumbing installation and are provided with a special high flow return fitting with a 1-1/2" pipe socket for installing 1-1/2" PVC pipe.

INSTALL RETURN FITTING (MODELS 2200 AND 2600)

Discard the **EYEBALL RETURN FITTING** provided with your skimmer and replace it with the **HIGH FLOW RETURN FITTING** as shown directing it away from the skimmer.

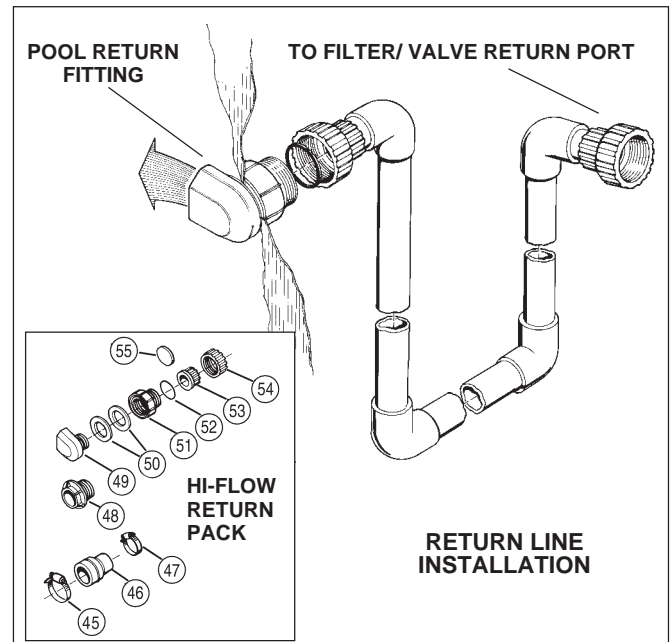

Locate a board large enough to cover return fitting cut-out. From inside of pool, use the board to hold liner against cut-out in pool wall. Keep hands away from hole to avoid injury. From outside of pool, use the cut-out as guide and cut away liner with a razor knife.

INSTALLATION

(without pressure type pool cleaner)

1. Slip a gasket (50) over the threads of the return fitting (49) and push threaded end through the wall from inside pool. Place the second gasket over the threads now exposed outside the pool.

2. Hold the return fitting (49) so the opening is facing away from the skimmer and slightly downward. Thread the union adaptor (51) onto the return fitting and tighten firmly. **Hint:** Using an oil filter wrench to tighten the union adaptor will make the job easier.

INSTALLATION

(with pressure type pool cleaner)

1. Slip a gasket (50) over the threads of the return fitting adaptor (48) and push threaded end through the wall from inside pool. Place the second gasket over the threads now exposed outside the pool.
2. Hold the return fitting adaptor (48) and thread the union adaptor (51) onto it and tighten firmly. **Hint:** Using an oil filter wrench to tighten the union adaptor will make the job easier.
3. Your pressure type pool cleaner will attach to the return fitting adaptor.

HARD PLUMB INSTALLATIONS

Using a 1-1/2" Schedule 40 PVC pipe with ends cut square, remove any burrs. Cut pipe to length as required between joints and loosely assemble for proper fit prior to solvent welding. Slip the union nut (54) onto the pipe with the female threads facing the union adaptor (51). Then, solvent weld the union socket (53) onto the pipe using primer and PVC/ABS solvent cement. **DO NOT** Allow solvent cement to contact the sealing surface of the union socket. When dry, assemble the connections and tighten firmly by hand.

Insert the o-ring (52) into the union adaptor groove, then secure the cemented pipe assembly onto the union adaptor (51) with the union nut (54).

SOLVENT WELDING

Contact your pool dealer for ABS to PVC Solvent Cement and PVC Primer and follow directions on labels.

TO WINTERIZE POOL

Drain pool down below the return fitting. Loosen union nut (54) and pull back the union socket (53). Insert the winterizing disc (55) between o-ring (52) and union socket. Retighten union nut onto union adaptor firmly.

INSTALL SUCTION LINE

An 8 foot long hose is provided for filter Model 1900 and a hard plumb adaptor with clamps for filter Models 2200 and 2600 for adapting hard plumbing to the skimmer outlet.

MODEL 1900 ONLY

The pump suction is provided with a hose barbed fitting and a 1-1/2" pipe socket fitting. Install the hose barbed fitting to the pump suction per the pump instructions and discard the socket fitting. Slip a hose clamp over each hose end and push one end onto skimmer outlet and the other end onto the pump suction port. Tighten clamps firmly using a flathead screwdriver or 5/16" nutdriver.

MODELS 2200 AND 2600

The pump suction is provided with a hose barbed fitting and a 1-1/2" pipe socket fitting. Use the socket fitting

and discard the barbed fitting. Refer to **HARD PLUMB INSTALLATION** and **SOLVENT WELDING** for assembling piping between skimmer and pump suction. Slip clamp onto small end of hard plumb adaptor and push onto skimmer outlet. Slip clamp onto large end of adaptor and insert pipe. Tighten clamps firmly.

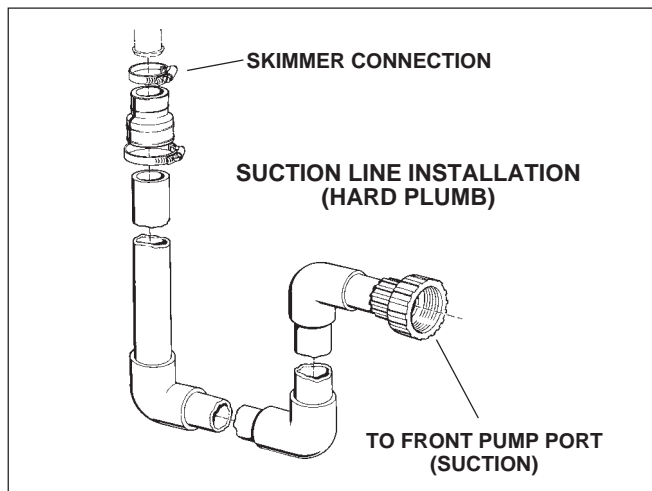

WASTE LINE HOOKUP

The discharge waste water will contain pool water treatment chemicals that may harm certain plants and vegetation. Therefore, position the discharge end of the waste line in a safe, out-of-sight area capable of accepting 200 to 400 gallons of waste water.

MODEL 1900

Install a 1-1/2" inside diameter waste discharge hose (not supplied) on the **waste** port located on the 6 position valve. Slip a 1-1/2" hose clamp (not supplied) over one end of the hose. Then, push hose onto the port fully and tighten clamp firmly.

IMPORTANT

The union plug (#340-2046) must be removed from the waste port and replaced with the union hose adaptor (#340-1969) prior to backwashing the filter. Replace the union plug after backwashing.

MODELS 2200 AND 2600

Loosen the waste port "Union Nut" and remove both the union nut and socket fitting. Caution: Take care not to lose the o-ring seated in the valve body. Slip union nut onto 1-1/2" PVC (N.P.S.) drainage pipe (not supplied) with female threads facing end of pipe. Then solvent weld the union socket onto the pipe end, using ABS to PVC Cement available at your pool store. Avoid allowing solvent to run onto the end sealing surface. Position onto the waste port, making sure o-ring is in place and firmly hand tighten union nut.

ELECTRICAL OUTLET

Refer to your pump owner's guide for detailed information pertaining to the requirements and regulations for safe electrical installation of the power supply, receptacle outlet, switching and ground fault interrupter.

FINISH FILLING POOL

Finish filling your pool, referring to skimmer installation and pool assembly instructions for proper water level.

VALVE OPERATION

Your new filter has six positions of operation, which are explained below. To change positions of the valve, make sure the pump is **OFF**. Press down on the valve handle enough to free the locking tab. Rotate the handle so the tab **LOCKS** in the desired position.

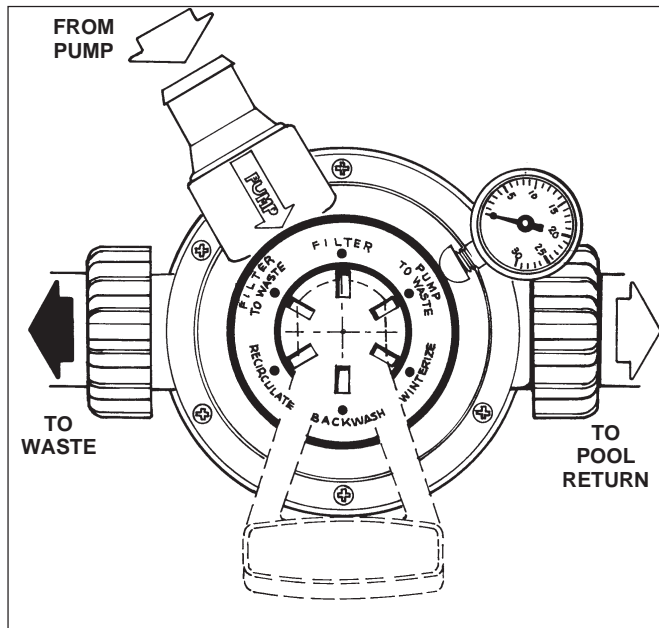

FILTER: Normal pool filtering position. May also be used when vacuuming the pool.

BACKWASH: Backwashing reverses the flow of water through the filter to flush out dirt and debris, and waste water is discharged to waste from the valve body port with sight glass. (Duration is normally 1-1/2 to 2 minutes or until water runs clear.)

FILTER TO WASTE: Place the valve handle in the "Filter to waste" position after backwashing your filter. (Normally, for only 10 seconds.)

PUMP TO WASTE: This position allows you to vacuum heavy debris or larger amounts of settled contaminants from the pool floor directly to waste.

RECIRCULATE POSITION: This position allows you to increase the water flow rate to circulate chemicals throughout the pool more quickly. Pool water passes through the valve on top of the filter bypassing internal filter components and travels back to the pool at a rapid rate.

WINTERIZE POSITION: This position allows you to drain trapped water from the filter valve and relieve compression on the rotor valve gasket during winter storage. **CAUTION:** Do not operate pump in this position as waste water contaminants will be discharged from the filter back into the pool.

INITIAL START UP

Before you begin filtering your pool, the filter sand must be backwashed thoroughly to remove the extra fine sand grains normally found in new filter sand.

1. Loosen the pump strainer pot lid to allow air to escape. Tighten lid when water begins to flow

2. Plug in your pump to the GFCI protected receptacle. Refer to "**WARNINGS**".
3. Push down on the valve handle and rotate to the **BACKWASH** position. Make sure valve handle indexes into the tabs on valve.
4. Start pump. During this initial start-up, allow 4-5 minutes to flush out the superfine sand grains to prevent them plugging the underdrain slots. Because pool water is lost during this operation (200 to 400 gallons) keep a close check on pool water level. Never let water level get so low that no water flows to pump. Replenish as required.
5. Stop pump. Push down on the valve handle and rotate to the **FILTER TO WASTE** position. Start pump and allow to run approximately 10 seconds to eliminate any "cloudy puff" out the return fitting inlet, then stop pump.
6. Push down on the valve handle and rotate to the **FILTER** position and start pump. Note the pressure reading on your pressure gauge for future reference of when to backwash.
7. Check all fittings and hoses for leaks and correct if necessary.

FILTER OPERATION

A newly filled pool is normally filled with unfiltered water and usually requires continuous filtering for 24 to 48 hours along with chemical treatment of the pool water. Because all pool installations vary in environmental conditions (wind, rain, airborne debris, heat and pool use, etc.), it is impossible to provide an accurate filtering time for normal usage. Use a trial and error method to determine how long your filter must operate each day. Generally, 6 to 8 hours of filtering each day is sufficient to maintain pool clarity if the pool chemical treatment is correct. As the water clears, the backwashing intervals will be extended (less frequent), allowing longer time periods between cleaning. Consult your local pool store for helpful advice in keeping your pool clean and sanitary.

When possible, avoid operating your filter during peak electricity demands in your community. Check with your local electric utility company for the best times they recommend for operating your filter pump.

WHEN TO BACKWASH

As your filter removes debris from the pool water during the filtering process, the return flow will gradually reduce. Backwash when the pressure gauge increases 5 to 7 pounds above the clean filter starting pressure.

VACUUMING YOUR POOL

When vacuuming your pool, debris is caught in the filter at a very rapid rate. Consequently, the filter must work harder, causing a rapid increase in filter pressure as will be indicated on the pressure gauge. Frequent backwashing could be necessary during this process depending on the amount of dirt being vacuumed off the

pool floor. Keep a check on the pool water level and refill as required.

MAINTENANCE

Preventative maintenance will provide continued, smooth performance and extend the life of your filter for many years. Neglect will cause parts to wear or bind, leaks to occur and result in costly repairs. Keep moving parts lubricated and a clean environment around your filter and related components.

LUBRICATION

There are various types of lubricants available. However, most are intended for moving metal parts. Unfortunately, these lubricants will harm or degrade plastics. **DO NOT** use petroleum base lubricants. Many people consider "PETROLEUM JELLY" safe for babies and can be applied to anything. But, it will **DESTROY** most plastics. Silicone lubricants are available at your pool dealer and are safe for use on plastics.

LUBE VALVE SHAFT

To lubricate the O-Ring on the valve shaft, depress valve handle fully and apply lubricant on the shaft between handle and valve cover. Then, rotate handle to distribute lubricant. Resume normal filter operation by rotating handle to the **Filter** position and start pump.

REPAIRS

Servicing should be performed by a qualified dealer. If disassembly is attempted, mark each of the parts assembled position as it relates to its mating parts. This assures proper alignment when reassembled. Malfunction will occur if not properly assembled. See your dealer for original replacement parts.

CAUTION

BEFORE removing filter or pump from pool for servicing, prevent the backflow of water from your skimmer and return inlet from flowing out of disconnected hoses.

1. Remove skimmer cover and basket and plug inside bottom hole with rag.

2. Referring to the instructions for your return inlet. Install the "SHUT-OFF" disc.
3. Disconnect hoses on filter or pump as necessary when removing for service or repairs.

DRAIN TANK See Caution Above

1. Remove tank clamp, valve assembly and o-ring from tank.
2. Remove tank drain cap to drain.
3. Place plastic bag over riser tube in tank and secure with a rubber band. Scoop out sand with a medium size can and place in plastic bag.
4. After servicing, reassemble and install in reverse. Make sure tank o-ring and sealing areas are free of any sand and that the o-ring is properly seated in the cover groove before replacing cover.

WINTERIZING FILTER

In areas subject to freezing damage, it is mandatory that the filter, pump and any related components be removed from the pool and stored indoors. (Refer to individual components owners guide such as pump, skimmer, chlorinator, etc., for specific winterizing instructions.)

1. Backwash the filter.
2. Siphon pool water level down below skimmer opening by using your vacuum hose and allow water to flow to an area that can accept a couple of thousand gallons or more.
3. Remove v-clamp from filter and remove cover and o-ring.
4. Remove tank drain cap and allow tank to drain fully.
5. Disconnect all hoses or piping.
6. Place plastic bag over riser tube in tank and secure with a rubber band. Scoop sand out with a medium size can and place in plastic bag. If sand is not badly contaminated, save for next season.
7. Store all components in a warm dry area indoors.

DAMAGE CAUSED BY FREEZING TEMPERATURES IS NOT COVERED BY PRODUCT WARRANTY.

EXPLODED VIEW MEDIA MASTER MODEL 1900

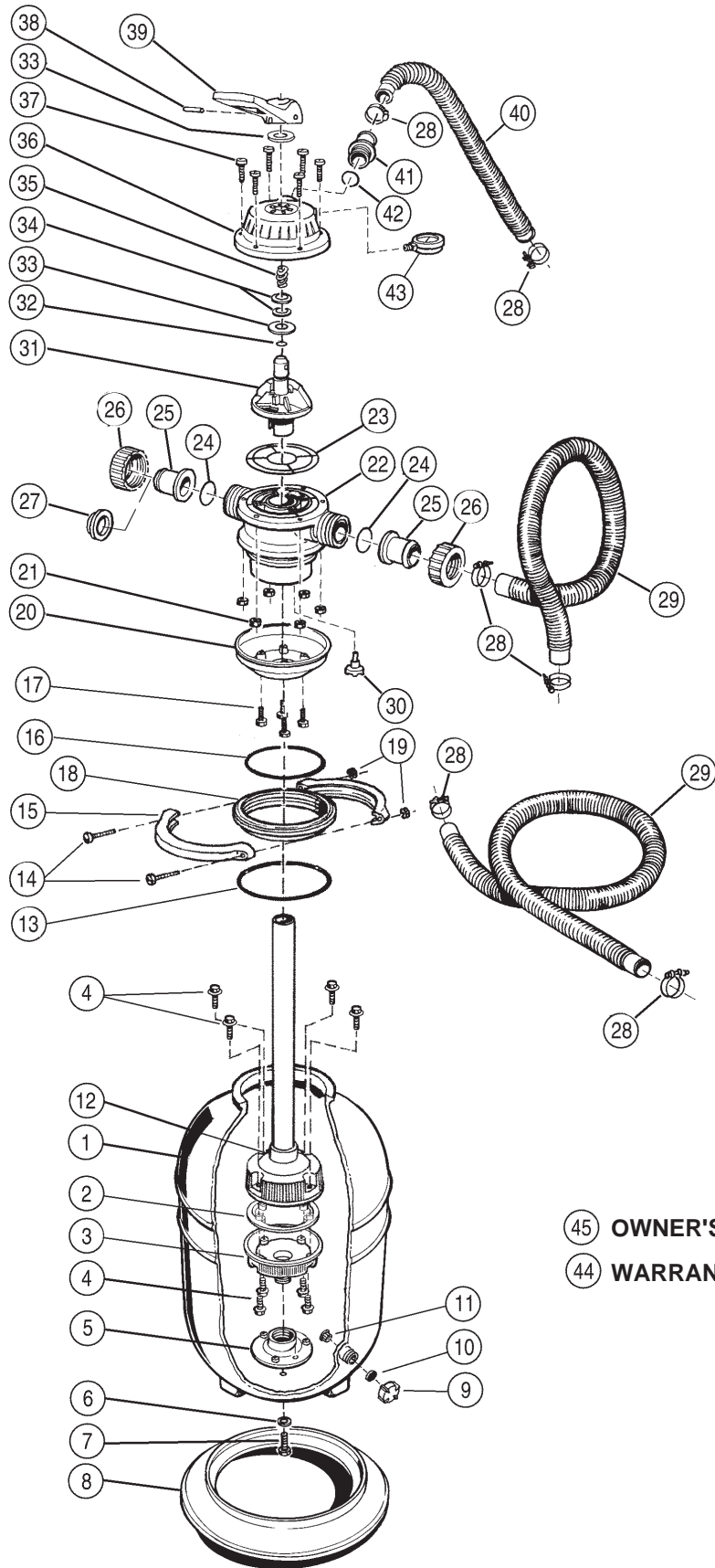

- 45 OWNER'S GUIDE
- 44 WARRANTY CARD

**PARTS LIST
MEDIA MASTER MODEL 1900**

ITEM	PART #	QTY	DESCRIPTION	ITEM	PART #	QTY	DESCRIPTION
*1	1121-1590	1	19" Tank	23	307-1022	1	Valve Gasket
2	340-2224	1	Underdrain Spacer	24	308-1241	2	O-Ring - 50mm I.D.
3	1107-1649	1	Threaded Underdrain Ass'y	25	340-1969	2	Union Hose Adaptor
4	330-1023	8	#8 x 5/8" Screw	26	340-1835	2	Union Nut
5	1121-1543	1	Tank Internal Adaptor w/ Insert and Screws	27	340-2046	1	Union Plug
6	308-1225	1	5/16" Thread Seal	28	387-1003	6	1-1/2" Wire Clamp
7	330-1245	1	5/16-18 x 1-1/4" Bolt	29	346-1035	2	1-1/2" x 8' Hose
8	340-2148	1	Tank Base	30	343-1100	1	Air Relief
9	340-1962	1	Drain Cap	31	340-2229	1	Valve Rotor
10	307-1001	1	Drain Cap Gasket	32	308-1044	1	O-Ring - .862 I.D.
11	340-2200	1	Sand Filter Drain Screen	33	327-1007	2	Friction Washer
12	1107-1648	1	Top Underdrain Assembly	34	327-1006	2	Bearing Washer
13	308-1252	1	O-Ring - 7.225 I.D.	35	396-1018	1	Spring
14	330-1260	2	1/4-20 x 1-1/2" Screw	36	1107-1486	1	Valve Cover w/Decal
15	340-2183	2	Tank Clamp	37	330-1234	6	12-24 x 1-1/4" Screw
16	308-1234	1	O-Ring - 5.850 I.D.	38	376-1050	1	Handle Pin
17	330-1024	4	#12 x 3/4" Screw	39	340-2228	1	Valve Handle
18	340-2175	1	Valve/Tank Adaptor	40	346-1053	1	1-1/2" x 4' Hose
19	321-1004	2	1/4-20 Hex Nut	41	340-1224	1	Hose Adaptor
20	340-2174	1	Upper Distributor	42	308-1039	1	O-Ring - 1.925 I.D.
21	330-1235	6	12-24 Hex Nut	43	395-1014	1	2" Pressure Gauge
**22	1121-1472	1	Valve Body/Gasket Ass'y	44	368-1073	1	Warranty Card (All Models)
				45	365-1824	1	Owner's Guide (All Models)

*Includes items 9, 10, & 11.

**Item #22 includes Items #23 and 30.

**EXPLODED VIEW
MEDIA MASTER MODELS 2200 and 2600**

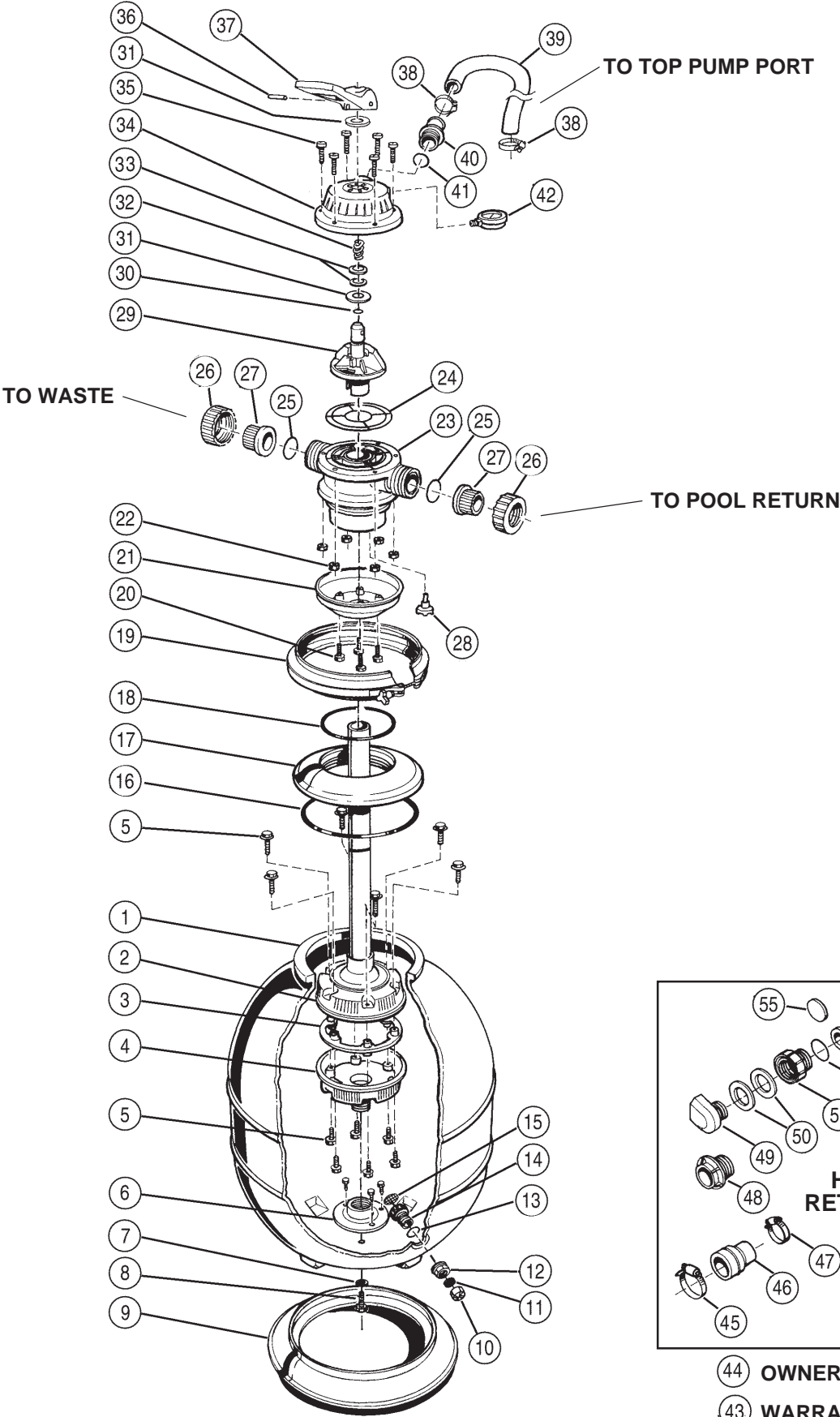

- 44 OWNER'S GUIDE
- 43 WARRANTY CARD

**PARTS LIST
MEDIA MASTER MODELS 2200 and 2600**

ITEM	PART #	QTY	DESCRIPTION	ITEM	PART #	QTY	DESCRIPTION
*1	1121-1541	1	22" Tank (Model 2200)	22	330-1235	6	12-24 Hex Nut
	1121-1542	1	26" Tank (Model 2600)	**23	1121-1472	1	Valve Body/Gasket Ass'y
2	1107-1491	1	Top Underdrain Assembly	24	307-1022	1	Valve Gasket
3	340-2096	1	Underdrain Spacer	25	308-1241	2	O-Ring - 50mm I.D.
4	1107-1575	1	Threaded Underdrain Ass'y	26	340-1835	2	Union Nut
5	330-1023	12	#8 x 5/8" Screw	27	340-1837	2	Union Socket
6	1121-1543	1	Tank Internal Adaptor w/ Insert and Screws	28	343-1100	1	Air Relief
7	308-1225	1	5/16" Thread Seal	29	340-2229	1	Valve Rotor
8	330-1245	1	5/16-18 x 1-1/4" Bolt	30	308-1044	1	O-Ring - .862 I.D.
9	340-2148	1	Tank Base	31	327-1007	2	Friction Washer
10	340-1962	1	Drain Cap	32	327-1006	2	Bearing Washer
11	307-1001	1	Drain Cap Gasket	33	396-1018	1	Spring
12	340-1970	1	Drain Fitting Nut	34	1107-1486	1	Valve Cover w/Decal
13	308-1206	1	O-Ring - 1.287 I.D.	35	330-1234	6	12-24 x 1-1/4" Screw
14	340-1957	1	Drain Fitting	36	376-1050	1	Handle Pin
15	340-1201	1	Sand Filter Drain	37	340-2228	1	Valve Handle
16	308-1251	1	O-Ring - 11.475 I.D.	38	387-1023	2	#28 Band Clamp
17	340-2017	1	Valve/Tank Adaptor	39	346-1049	1	1-1/2" x 4' Hose
18	308-1234	1	O-Ring - 5.850 I.D.	40	340-1224	1	Hose Adaptor
19	387-1030	1	V-Clamp	41	308-1039	1	O-Ring - 1.925 I.D.
20	330-1024	4	#12 x 3/4" Screw	42	395-1014	1	2" Pressure Gauge
21	340-1190	1	Upper Distributor	43	368-1073	1	Warranty Card
				44	365-1824	1	Owner's Guide

*Item #1 includes Items #10 through #15.

**Item #23 includes Items #24 and 28.

**HI-FLOW RETURN PAK & PARTS
(MODELS 2200 AND 2600 ONLY)**

ITEM	PART #	QTY	DESCRIPTION	ITEM	PART #	QTY	DESCRIPTION
45	387-1024	1	#36 Band Clamp	51	340-2052	1	Union Adaptor
46	348-1036	1	Hard Plumb Adaptor	52	308-1241	1	O-Ring - 50mm I.D.
47	387-1023	1	#28 Band Clamp	53	340-2047	1	Union Socket
48	340-1791	1	Return Fitting Adaptor	54	340-2048	1	Union Nut
49	340-2051	1	Return Fitting	55	340-2099	1	Winterize Disk
50	308-1110	2	Return Gasket				

TROUBLESHOOTING SAND FILTERS

PROBLEM	POSSIBLE CAUSE	REMEDIES
1 - High gauge pressure, low return flow.	<ol style="list-style-type: none"> 1 - Insufficient backwashing. 2 - Excessive contaminants or algae in sand. 3 - Filter sand is too fine. 4 - Underdrain plugged. 	<ol style="list-style-type: none"> 1&2 - Backwash filter. 3 - Use #20 filter sand. 4 - Replace sand after cleaning underdrain slots.
2 - Low gauge pressure, low flow. Pump suction drawing in air. Pump sounds like marbles rattling in it.	<ol style="list-style-type: none"> 1 - Water level too low in pool. 2 - Restriction on suction side of pump. 3 - Skimmer or strainer basket filled with debris. 	<ol style="list-style-type: none"> 1 - Fill pool so water is between marks on skimmer face plate. 2 - Clear obstruction in skimmer, hoses or pump. 3 - Clean skimmer and strainer baskets.
3 - High flow, low or normal gauge pressure but pool water will not clear up.	<ol style="list-style-type: none"> 1 - Pool water is chemically out of balance. 2 - Sand too coarse. 3 - Sand grains rounded or worn. 	<ol style="list-style-type: none"> 1 - Check with test kit or contact dealer. 2 - Use #20 filter sand. 3 - Use crushed #20 filter sand.
4 - Short filter cycles.	<ol style="list-style-type: none"> 1 - Excessive contaminants or algae in sand or pool. 2 - Improper backwashing. 3 - Sand too fine. 	<ol style="list-style-type: none"> 1 - Check chemical balance. Filter will require frequent backwashing. 2 - Backwash filter thoroughly. Waste hose too long or restricted. 3 - Replace sand with #20 filter sand.
5 - Sand entering pool.	<ol style="list-style-type: none"> 1 - Defective underdrain. 2 - Sand too fine. 	<ol style="list-style-type: none"> 1 - Replace underdrain. 2 - Use #20 filter sand.
6 - Water leaking to waste.	<ol style="list-style-type: none"> 1 - Valve not seated in filter position. 2 - Defective gasket in valve body. 	<ol style="list-style-type: none"> 1 - Actuate valve handle and make sure valve is seated. 2 - Replace gasket or contact dealer.

Note: Contact your pool dealer for any problems you cannot solve.

Change of Design: Doughboy Recreational expressly reserves the right to change or modify the design and construction of any product in due course of our manufacturing procedures, without incurring any obligation or liability to furnish or install such changes or modifications on products previously or subsequently sold.



"the original portable pool"

doughboy®

DOUGHBOY RECREATIONAL • 10959 Jersey Blvd., • Rancho Cucamonga, CA 91730-5194
 Visit our website at www.doughboy-pools.com