

# INFINITY™ FILTER

Rotary DE Filter

Models 1-2670-069

---

---

**Owner's Guide**

---

---

## **⚠ WARNING**

**“READ ALL INSTRUCTIONS.” Failure to follow these important safety instructions and other basic safety precautions may result in serious personal injury.**

# IMPORTANT SAFETY INFORMATION

## CAUTION

Do not install pump and filter system where flooding may occur. This could damage the pump motor.

## WARNING

**SEVERE ELECTRICAL SHOCK** could result if you install your filter and pump on a deck or above pool water level. They could fall into the water, causing severe shock or electrocution. **DO NOT** install on a deck or other surface at, above or slightly below the top rail of the pool.

## INSTALLED LOCATION

Install filter, pump and any related components a minimum of 5 feet from pool to prevent their being used as steps to climb into the pool by young children. **DO NOT** store toys, chairs, tables, containers or other objects within 5 feet of the pool for the same reason.

Do not allow children or adults to climb, sit or stand on the filter or pump. They could easily fall and injure themselves.

## ACCESSIBILITY

The circulation system components should be installed to allow accessibility for inspection, repair or replacement. **DO NOT** alter the pump electrical cord in any way or change the plug end to any other style. **DO NOT** use an extension cord(s). Severe electrical shock may occur.

## PROPERLY SUPPORTED

The filter, pump and any other related

components should be properly supported to prevent damage from misalignment, settlement or vibration and be mounted to minimize the potential for the accumulation of debris and moisture.

## PREVENT SEVERE SHOCK

To prevent the risk of severe electrical shock, plug your pump cord end into a grounding type receptacle protected by a ground fault circuit interrupter (GFCI). Contact a qualified electrician if you cannot verify that the receptacle is protected by a GFCI.

**DO NOT** allow children to operate or play around this product unless they are closely supervised by adults at all times.

Replace damaged cord immediately to reduce the risk of electrical shock.

## DO NOT BURY CORD

An unexposed cord may accidentally become damaged or severed by a sharp object or shovel resulting in severe electrical shock. Position cord to prevent accidental damage from lawn mowers, hedge trimmers or other equipment.

## BARE FEET/WET GROUND

This is a dangerous combination around electrical equipment. Always be sure the ground under your feet and body is dry before you touch the filter and pump or any electrical equipment near the pool. Failure to heed this warning may cause severe

personal injury or electrocution due to severe electrical shock.

## LOCAL CODES

Local building codes may require obtaining an electrical or building permit. Contact your local building department for applicable codes or regulations governing the installation of swimming pool equipment.

## ELECTRICAL

To avoid electrical shock and prevent damage to your pump motor, it is recommended that you have a qualified electrical contractor install the electrical power supply as specified in your pump instructions.

## WARNING

Avoid direct water spraying with a garden hose near electrical outlets, pump or any other electrical devices. Severe electrical shock or electrocution may occur.

## SERVICING YOUR PUMP

Always unplug your pump from the receptacle before servicing, adjusting or repairing your filter system.

**INFINITY DE  
FILTER COMPONENT PARTS LIST  
MODEL NUMBER 1-2670-069**

ITEM	P/N	QTY	DESCRIPTION
1	1121-1833	1	Tank Assembly
2	340-1982	1	Drain Fitting
3	308-1206	1	O-Ring 1.475 x .210
4	340-2161	1	Washer - Storm Gray
5	340-1980	1	Drain Fitting Nut
6	340-2105	1	Drain Cap
7	307-1001	1	Drain Cap Gasket (not shown)
8	308-1225	1	5/16" Thread Seal
9	330-1219	1	5/16"-18 x 1 S.S. Hex Bolt
10	1121-1832	1	Lower Manifold Assembly
11	1119-1046	5	D.E. Grid Assembly
12	340-1314	1	Grid Collector
13	1107-1687	1	Valve/Grid Adapter
14	1107-1689	1	Inlet Assembly
15	387-1030	1	V-Clamp/Filter
16	308-1251	1	Tank O-Ring Gasket
17	340-2104	1	Valve/Tank Adapter
18	308-1234	1	O-Ring 5.850" I.D. x .250 O-Ring
19	1121-1834	1	6 Position D.E. Valve
20	395-1014	1	Pressure Gauge
21	346-1019-1	1	1-1/2" x 48" Hose
22	346-1037-1	2	1-1/2" x 96" Hose
23	387-1017	6	#20 S.S. Hose clamp
24	321-1027	6	Hex Nut
25	1121-1835	1	Threaded Valve Body
26	307-1033	1	Gasket
27	340-2381	1	Distributor
28	327-1071	1	Delrin washer
29	327-1006	1	S.S. washer
30	396-1023	1	Spring
31	327-1006	1	S.S. washer
32	327-1070	1	Delrin Washer
33	308-1268	1	O-ring
34	340-2376	1	Valve Cover
35	330-1059	6	Screws
36	378-1026	1	S.S. handle pin
37	327-1070	1	Delrin washer
38	340-2375	1	Valve handle
39	365-1905	1	Owner's Guide
40	—	1	Warranty Card

## TROUBLE SHOOTING CHECKLIST

PROBLEMS	POSSIBLE CAUSE	REMEDIES
1. High gauge pressure Low return flow.	<ol style="list-style-type: none"> <li>1. Filter needs backwashing</li> <li>2. Excessive contaminants or algae on grids.</li> <li>3. Calcium crustation on grid cloth.</li> </ol>	<ol style="list-style-type: none"> <li>1. Backwash filter.</li> <li>2. Backwash filter or contact dealer.</li> <li>3. Disassemble and wash grids with 1 part muriatic acid to 4 parts of water.</li> </ol>
2. Low gauge pressure, low flow (Bubbles from return fitting or pump has rattling noise in it).	<ol style="list-style-type: none"> <li>1. Pool water level too low.</li> <li>2. Restriction on suction side of pump.</li> <li>3. Skimmer or strainer basket filled with debris.</li> <li>4. Loose strainer pot lid.</li> </ol>	<ol style="list-style-type: none"> <li>1. Fill pool so water is between water lines on skimmer.</li> <li>2. Clear obstruction in skimmer, hoses or pump.</li> <li>3. Clean skimmer and /or strainer baskets.</li> <li>4. Tighten strainer pot lid.</li> </ol>
3. High flow, low or normal gauge pressure but pool water will not clear up.	<ol style="list-style-type: none"> <li>1. Pool water is chemically out of balance.</li> <li>2. Opening in grid cloth</li> <li>3. Filter grids not properly seated.</li> </ol>	<ol style="list-style-type: none"> <li>1. Check with test kit or contact dealer.</li> <li>2. Replace defective grid.</li> <li>3. Tighten grid assembly.</li> </ol>
4. Short filter cycles.	<ol style="list-style-type: none"> <li>1. Excessive amounts of suspended contaminants or algae.</li> <li>2. Calcium crustation on grid cloth.</li> </ol>	<ol style="list-style-type: none"> <li>1. Filter will require frequent backwashing until water is clear.</li> <li>2. Disassemble and wash grids with 1 part of muriatic acid to 4 parts of water.</li> </ol>
5. Cloudy puff out of return fitting.	<ol style="list-style-type: none"> <li>1. Extra fine particles of D.E.</li> <li>2. Open seam or hole in grid.</li> </ol>	<ol style="list-style-type: none"> <li>1. Place valve handle in Filter to Waste position when turning on pump and when precoating grids with D.E.</li> <li>2. Replace grid.</li> </ol>
6. Water leaking to waste.	<ol style="list-style-type: none"> <li>1. Valve handle misaligned</li> <li>2. Defective gasket in valve body.</li> </ol>	<ol style="list-style-type: none"> <li>1. Realign valve handle.</li> <li>2. Replace gasket or contact dealer.</li> </ol>

Note: Contact your Lomart dealer for any problems that you cannot solve.

**Change of Design:** Lomart Industries expressly reserves the right to change or modify the design and construction of any product in due course of our manufacturing procedures, without incurring any obligation or liability to furnish or install such changes or modifications on products previously or subsequently sold.



The Single  
Source Supplier  
**Lomart**  
A Division of Hoffinger Industries, Inc.

**LOMART INDUSTRIES**  
315 N. Sebastian St. • West Helena, AR 72390  
Visit our website at [www.lomart.com](http://www.lomart.com)

## HOW YOUR FILTER WORKS.

The pump draws pool water through the skimmer and traps large floating debris in the skimmer basket. The water then passes through the pump and into the filter. The filter's Diatomaceous Earth and grids strain out small particulates (dirt) and allow clean water to return to the pool through the return fitting. When your filter becomes loaded with these particulates, the pressure inside gradually builds, slowing down the flow. The pressure gauge indicates

when the filter needs backwashing (cleaning). A simple valve change into the backwash position reverses the flow through the filter. This flushes out the collected particulates and contaminated D.E.. The frequency between backwashes depends on the local environment, and airborne or carry-in debris by swimmers.

Before you begin installing your filter, refer to your pump owners guide for important installation and electrical information related to your filter.

## TOOLS REQUIRED

1. Common Screwdriver
2. Small Crescent Wrench
3. Carpenter's Level
4. Shovel
5. Tape Measure
6. 5/16" nutdriver (optional)

## MATERIALS REQUIRED

1. Diatomaceous Earth (D.E.). See your dealer.
2. Nine - 8" x 12" x 2" Patio Blocks.
3. 1-1/2" Diameter Waste Discharge Hose.

## SITE PREPARATION

Install the filter and pump a minimum of 5 feet from the pool wall so they may not be used as steps by children. Position the filter and pump foundation between skimmer and return fitting. Level a 24" x 36" area and place patio blocks as shown in Fig. 1.

Level the patio blocks in all directions using a carpenter's level.

With the valve in the filter position, place the filter tank on the patio blocks and position it so the valve handle is facing away from the pool.

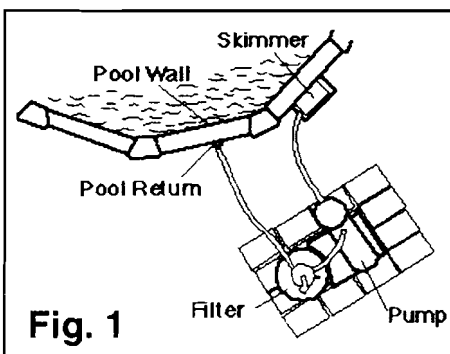

Place the pump to the right of the filter as shown in Fig. 1.

## INSTALL HOSES

See Fig. 1 and Exploded Parts Illustration

**IMPORTANT:** Incorrect hose hook-up could cause damage to your filter system. Follow the instructions below carefully.

Suction and return lines should be partially buried to prevent accidental tripping that could cause personal injury or damage to the filter system. Be sure the hoses are routed so that water flow through them is not restricted.

Starting at least 12" from the pool wall, make two 3-4" deep trenches, one from near the pool skimmer to the front of the pump, and the other from the pool's return fitting to the front of the filter pad beneath the valve's return port.

The two 8 ft. long hoses are interchangeable and used for the suction and return lines. Slip a hose clamp over the ends of each hose prior to installing. Connect one long hose (suction line) between the pool skimmer and front pump port.

Connect the other long hose (return line) between the pool's return fitting and valve port marked "RETURN." Connect the short hose between the pump discharge port (located at top of pump) and the valve's pump port, marked "PUMP." Tighten clamps firmly using a flathead screwdriver or 5/16" nutdriver. Cover the trenches with a firm board when finished.

**NOTE:** Do not completely bury the

hoses with dirt.

## VALVE OPERATION

To set the correct valve position, stop pump, push down on handle and rotate to the desired position. Make sure the handle is engaged in the slot.

### VALVE HANDLE POSITIONS:

**Filter:** For normal filtration and vacuuming.

**Backwash:** To flush out debris from filter tank. Water is discharged through waste port. Use for two minutes or until water runs clear.

**Filter To Waste:** To flush residual debris after backwashing. Water is discharged through waste port. Use for 20 seconds.

**Pump To Waste:** For lowering pool water level and vacuuming when pool is very dirty.

**Closed:** For shutting off flow to filter for servicing. Do not operate pump in this position.

**Recirculate:** Increases flow by bypassing filter to rapidly circulate unfiltered water after adding chemicals.

## INITIAL START UP

1. Loosen strainer pot lid to allow air to escape. Tighten lid when water begins to flow between strainer pot lid and strainer body. Do not overtighten.
2. Rotate the rotor valve handle to the closed position. Slip one end of the waste hose (not provided) over the waste port adapter and place other end in a convenient drainage location. See CAUTION in BACKWASH section.

# INFINITY DE FILTER

## FILTER COMPONENTS

### EXPLODED VIEW

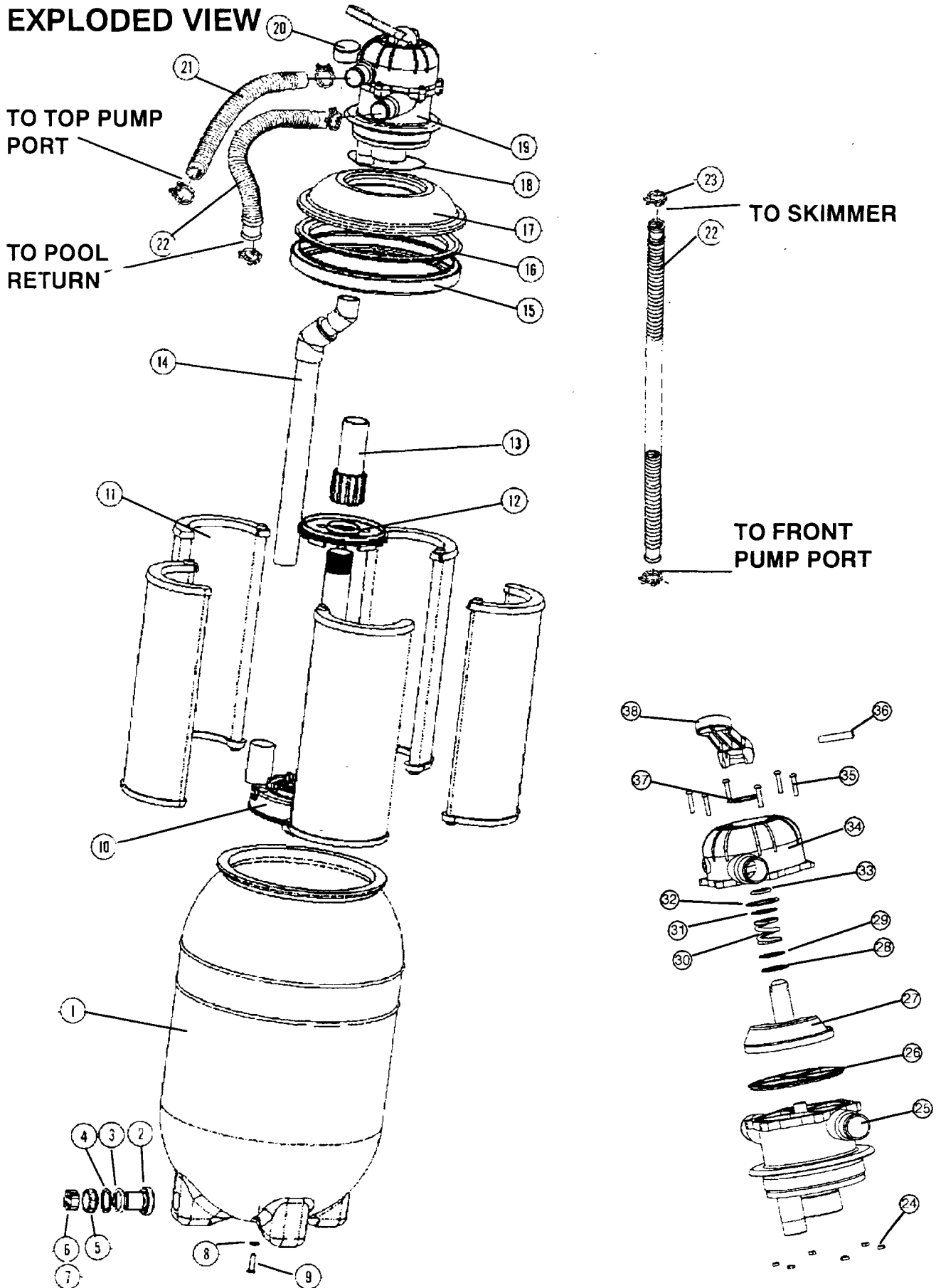

3. **Never operate the filter without Diatomaceous Earth.** D.E. may be purchased at your pool store. To coat the filter grids with D.E., you will need a minimum of 1-1/2 pounds for initial start up. Rotate rotor valve handle to the "Filter to Waste" position.

4. Plug in your pump to the GFCI protected receptacle. Refer to Safety Information.

5. Start pump.

6. Remove the pool's skimmer lid. Very slowly pour 1-1/2 pounds of D.E. into the skimmer opening. (A clean one pound coffee can holds 1/2 pound of D.E. Your filter will require three coffee cans full).

7. **During this process, super fine particles of D.E. migrate through the grids and to waste. After 30 seconds, stop pump and rotate handle to "Filter" position. Remove waste hose. Start pump.**

8. Check the pressure gauge and note the reading. Using a permanent marking pen, mark your gauge at a pressure 5 to 7 pounds higher than the present reading. When pressure reaches the marked point on the pressure gauge, it is time to backwash your filter.

9. Check all fittings and hoses for any leaks and correct if necessary.

The water should be filtered 24 hours a day for the first one to two days only, and accompanied by chemical treatment. Consult your local pool store for helpful advice in keeping your pool clean and sanitary.

## GENERAL OPERATION

Because all pools are subjected to varying environmental conditions (wind, rain, airborne debris, heat, pool use, etc.), it is impossible to provide an accurate filtering time for normal usage. Use a trial and error method to determine how long your filter must operate each day.

**Generally 6 - 8 hours of filtering each day is sufficient to maintain pool water clarity.**

During initial start up, and when conditions warrant additional filtering time, your filter may require frequent backwash intervals. As the water clears, the backwashing intervals will be extended, allowing longer time periods between cleaning.

## BACKWASH (Clean Filter)

1. The filter should be backwashed when the flow through your filter is noticeably reduced, or when the pressure gauge needle reaches the previously marked position (5-7 lb.s above clean filter operating pressure).

2. Stop pump. Slip one end of waste hose (not provided) over the waste port adaptor and place other end in a convenient drainage area.

## CAUTION

Because pool water contains chemicals that may harm certain plants and vegetation, you should route the waste hose to an area that is safe for vegetation, and that can safely receive up to 100-150 gallons of water. There may be restrictions in your locality regarding the disposal of pool water. Follow all local codes and ordinances when backwashing or draining your pool.

3. Rotate filter valve handle to "Backwash" position. Start pump and backwash for at least 2 minutes or until water runs clear from waste hose. Stop pump, wait 30 seconds, and start pump. Do not backwash longer than necessary.

4. Stop pump. Rotate valve handle to Filter to Waste position and start pump. Recoat grids with 1-1/2 pounds of D.E. Stop pump and rotate valve to "Filter" position. Start pump. Your filter is now operating in a "clean" condition.

## VACUUMING YOUR POOL

1. Stop pump.

2. Remove any large debris from pool.

3. Clean pump strainer basket. See Cleaning Strainer Basket in your pump owner's guide.

4. Connect waste hose.

5. Follow your vacuum manufacturer's owner's guide for vacuum hose and head assembly.

6. Follow your skimmer manufacturer's owner's guide for vacuum hose attachment to skimmer and skimmer preparations.

7. Start pump and vacuum your pool. Refer to filter's pressure gauge frequently during vacuuming. Rapid increases in pressure may occur. If so, backwash your filter. If your pool is excessively dirty, we recommend vacuuming with your filter in the "Waste" position. Because pool water is lost during this operation, keep a close check on your pool water level. Replenish water as required.

8. When finished, return skimmer and filter to normal operation.

## WINTERIZING

1. Backwash the filter.
2. Rotate valve handle to waste position and run until water stops discharging from the waste hose. Stop pump. To avoid pump failure, do not allow pump to continue running without water. Siphon the pool water down with your vacuum hose until water level is below the pool wall openings.
3. To drain water from filter, depress the handle and rotate until handle pointer is on any raised portion of the index hub.
4. Remove bottom drain plug and drain all water out of tank. Replace drain plug.
5. Disconnect all hoses. Remove tank cover. Lift off cover, set aside and hose off grids.
6. Dry out the inside of the tank and store filter, hoses and pump in a warm dry area.

## SERVICING

Servicing should be handled by a qualified dealer.

If disassembly is attempted, mark each parts assembled position as it relates to its mating part. This assures proper alignment when reassembled. Malfunction will occur if not properly assembled. See your Lomart dealer for original equipment manufactured (OEM) parts and servicing.