



# Timberline II

## Buttress Oval Pool

---

### Parts List



# Timberline II Buttruss Oval Pool — Parts List

| ITEM # | DESCRIPTION                                             | 20' x 12' x 48" |      | 24' x 12' x 48" |      |
|--------|---------------------------------------------------------|-----------------|------|-----------------|------|
|        |                                                         | PART #          | QTY. | PART #          | QTY. |
|        | <b>ASSEMBLY PACK</b>                                    | 0-9902-400      | 1    | 0-9942-400      | 1    |
| 1.     | Plastic Coping, 24"                                     | 545-1001        | 30   | 545-1001        | 33   |
| 2.     | Vertical End Cap                                        | 580-1594        | 24   | 580-1594        | 26   |
| 3.     | Stabilizer Rail, small dia.                             | 583-1012        | 8    | 583-1012        | 8    |
| 4.     | Stabilizer Rail, large dia.                             | 583-1011        | 10   | 583-1011        | 12   |
| 5.     | Bottom Rail (Stamped 12)                                | 589-1046        | 12   | 589-1046        | 12   |
| 6.     | Bottom Rail, side (Stamped S)                           | 589-1052        | 2    | 589-1052        | 4    |
| 7.     | 4" Outer Connector                                      | 580-1546        | 14   | 580-1546        | 16   |
| 8.     | Inner Connector                                         | 5186-1186       | 14   | 5186-1186       | 16   |
| *9.    | Sheet Metal Screw #10 x 3/8"<br>Hexwasher Head, Type AB | 510-1000        | 100  | 510-1000        | 100  |
| 10.    | Pool Parts List                                         | 573-2817        | 1    | 573-2817        | 1    |
| 11.    | Pool Installation Instructions                          | 573-2823        | 1    | 573-2823        | 1    |
| 12.    | "Read Me First" Booklet                                 | 573-2777        | 1    | 573-2777        | 1    |
| 13.    | "Enjoy Your Pool" Booklet                               | 573-2743        | 1    | 573-2743        | 1    |
| 14.    | "Safety First" Booklet                                  | 573-2778        | 1    | 573-2778        | 1    |
| 15.    | "Children Aren't . . ." Brochure                        | 573-2338        | 1    | 573-2338        | 1    |
| 16.    | "Pool & Spa . . ." Brochure                             | 573-2393        | 1    | 573-2393        | 1    |
| 17.    | Warranty Card - Metal                                   | —               | 1    | —               | 1    |
| 18.    | Product Registration Card                               | 565-1117        | 1    | 565-1117        | 1    |
|        | <b>TOP RAIL PACK</b>                                    | 0-9841-400      | 1    | 0-9861-400      | 1    |
| 19.    | Top Rail                                                | 587-1192        | 14   | 587-1192        | 16   |
|        | <b>VERTICAL PACK</b>                                    | 0-9710-400      | 1    | 0-9710-400      | 1    |
| 20.    | Vertical                                                | 580-1156        | 10   | 580-1156        | 10   |
|        | <b>POOL LINER CARTON</b>                                |                 |      |                 |      |
| ***21. | Pool Liner                                              | 0-2012-___      | 1    | 0-2412-___      | 1    |
| 22.    | Chlorine/Winterizing Instructions                       | 573-2421        | 1    | 573-2421        | 1    |
| 23.    | "Warning" Decal                                         | 560-1041        | 3    | 560-1041        | 3    |
| 24.    | Warranty Card - Liner                                   | —               | 1    | —               | 1    |
| **25.  | Repair Patch                                            | 564-1000        | 1    | 564-1000        | 1    |
| 26.    | "Deeper Area" Decal                                     | 560-1042        | 2    | 560-1042        | 2    |
| 27.    | "Shallow" Decal                                         | 560-1043        | 3    | 560-1043        | 3    |
| 28.    | "Read Me First" Booklet                                 | 573-2777        | 1    | 573-2777        | 1    |
|        | <b>SIDEWALL CARTON</b>                                  |                 |      |                 |      |
| 29.    | Sidewall                                                | 0-0008-002      | 1    | 0-0008-042      | 1    |
| 30.    | Joint Piece                                             | 580-1002        | 1    | 580-1002        | 1    |
| 31.    | Warranty Card - Metal                                   | —               | 1    | —               | 1    |
| 32.    | "Warning" Sign                                          | 560-1046        | 1    | 560-1046        | 1    |
| 33.    | "Read Me First" Booklet                                 | 573-2777        | 1    | 573-2777        | 1    |
| 34.    | Black Marking Pen                                       | 332-1079        | 1    | 332-1079        | 1    |
| 35.    | Adhesive Squares                                        | 310-1034        | 6    | 310-1034        | 6    |
| 36.    | Safety Video                                            | 573-2500        | 1    | 573-2500        | 1    |
|        | <b>SUPPORT PACK 4 — CARTON</b>                          | 0-8888-034      | 1    |                 |      |
|        | <b>SUPPORT PACK 6 — CARTON</b>                          |                 |      | 0-8888-036      | 1    |
| 37.    | Side Vertical                                           | 580-1614        | 4    | 580-1614        | 6    |
| 38.    | Vertical Brace                                          | 580-1173        | 4    | 580-1173        | 6    |
| 39.    | Bottom Rail Connector                                   | 580-1792        | 4    | 580-1792        | 6    |
| 40.    | Horizontal Support                                      | 580-1275        | 4    | 580-1275        | 6    |
| 41.    | Support Bracket                                         | 580-1136        | 4    | 580-1136        | 6    |
| 42.    | Pressure Pad                                            | 580-1273        | 4    | 580-1273        | 6    |
| 43.    | Brace, Connector — short                                | 580-1176        | 4    | 580-1176        | 6    |
| 44.    | Brace, Connector — long                                 | 580-1051        | 4    | 580-1051        | 6    |
| 45.    | Skid Plate                                              | 580-1063        | 4    | 580-1063        | 6    |
| *46.   | Sheet Metal Screw, #10 x 3/8",<br>Type AB               | 510-1000        | 92   | 510-1000        | 138  |
| *47.   | High Strength Bolt 1/4"-20 x 1/2",<br>hex head          | 510-1018        | 72   | 510-1018        | 108  |
| *48.   | Hex Nut, 1/4-20                                         | 511-1000        | 72   | 511-1000        | 108  |
| *49.   | Hex Washered/Sheet Metal<br>Screw, # 12 x 3/4"          | 510-1035        | 16   | 510-1035        | 24   |
| 50.    | Horizontal End Cap                                      | 580-1412        | 4    | 580-1412        | 6    |

\*Screws are available in most hardware stores.

\*\*For additional patch kits order Part No. 0-5604-000.

\*\*\*Write the number of your liner in the spaces provided here and above. # \_\_\_\_\_.

# EXPLODED VIEW

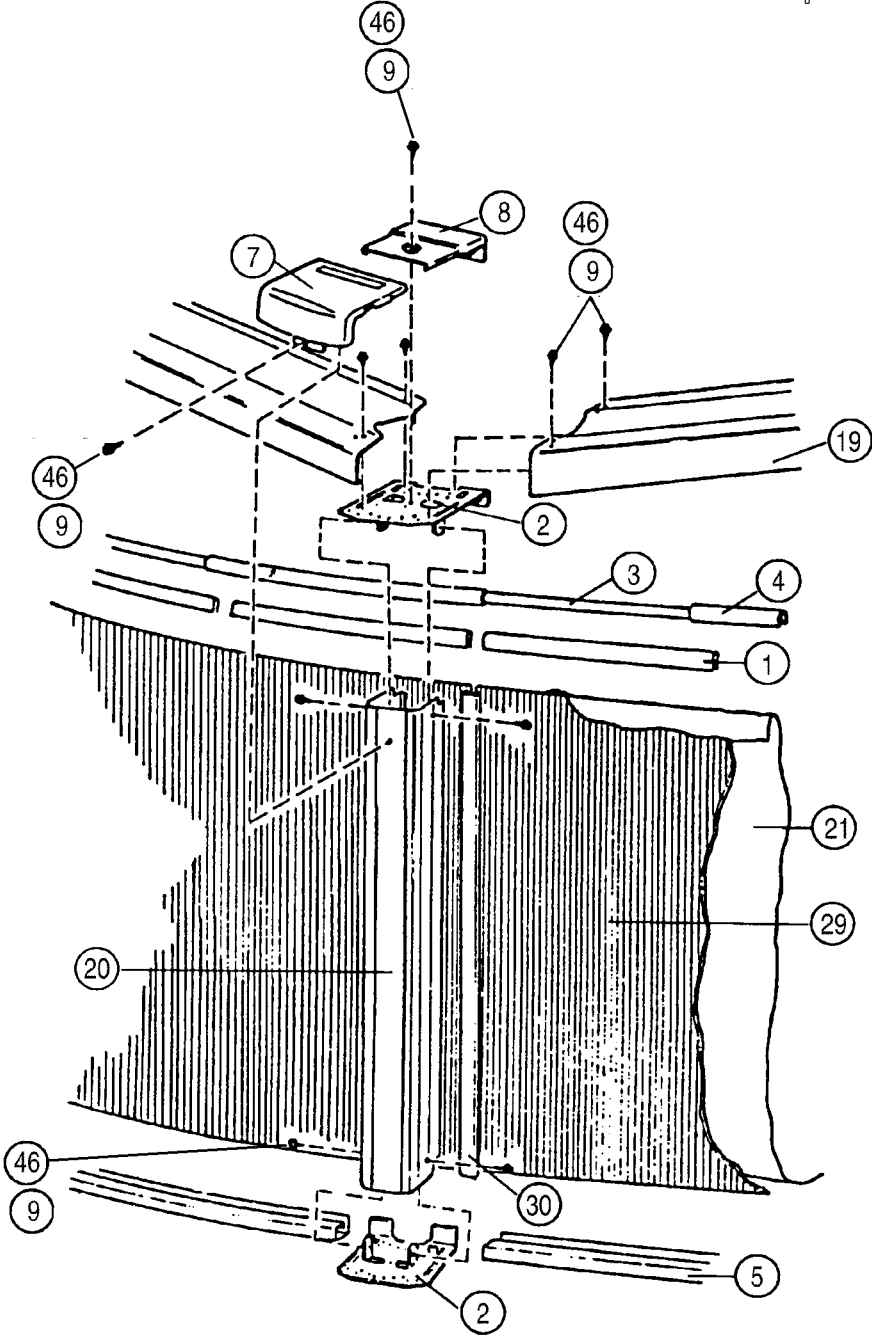
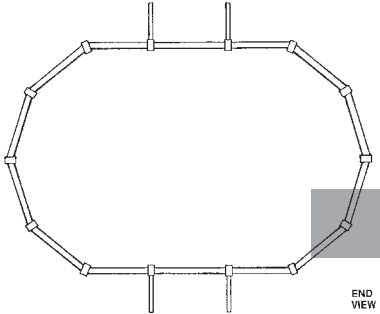

# EXPLODED VIEW

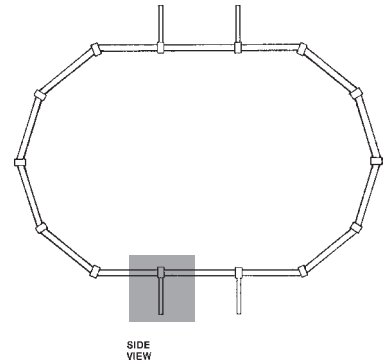
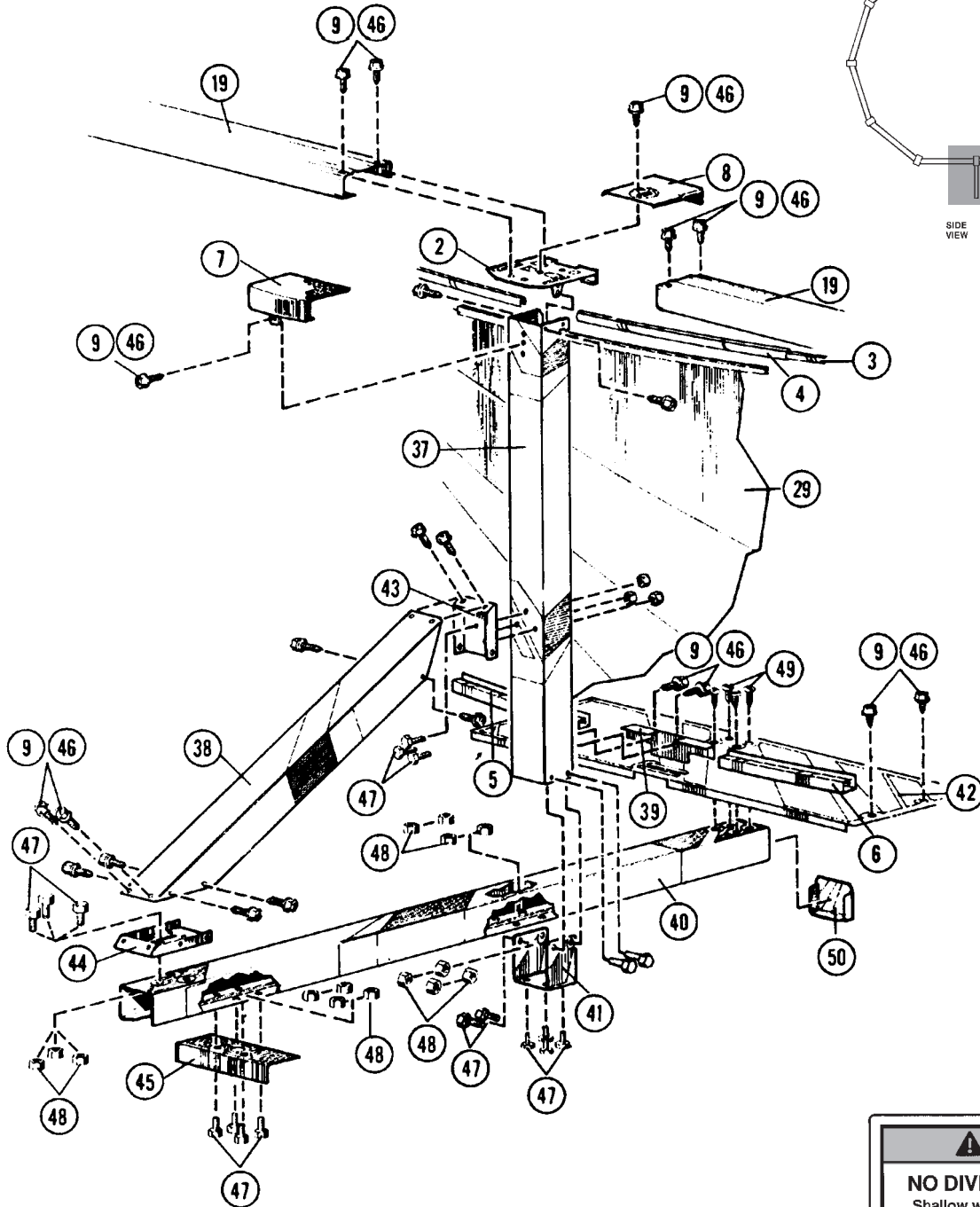

Change of Design: Doughboy Recreational expressly reserves the right to change or modify the design and construction of any product in due course of their manufacturing procedures, without incurring any obligation to furnish or install such changes or modifications on products previously or subsequently sold.

| <b>WARNING</b>                                                                                                                                                  |                                                                                                                                                  |
|-----------------------------------------------------------------------------------------------------------------------------------------------------------------|--------------------------------------------------------------------------------------------------------------------------------------------------|
| <b>NO DIVING!</b><br>Shallow water.<br><br>You can be permanently injured. | <b>PREVENT DROWNING</b><br><br>Watch children at all times. |
| RESCUE: _____                                                                                                                                                   |                                                                                                                                                  |

"the original portable pool"

# doughboy®

**DOUGHBOY RECREATIONAL • 10959 Jersey Blvd. • Rancho Cucamonga, CA 91730**

DB 695-035

Made in the United States of America

Copyright © 1995